

Water Purifiers | Standard, Large, Slim

WG253/1013, WGS201

Distillation capacity	1.5L/h (WG253/WGS201)	5L/h (WG1013)	Collection method	Ion exchange method → Distillation method → Filtration method	Purified water collection	Ion-exchange water/Distilled water	Water quality level	A4 (Ion-exchange water)/A4 (Distilled water)
-----------------------	-----------------------	---------------	-------------------	---	---------------------------	------------------------------------	---------------------	--

High-performance pure water system that reduces TOC levels and complies with JIS K 0557 A4 standards.

Features

- High-purity water is produced through ion exchange → distillation → filtration.
- A pretreatment column (activated carbon + 0.1μm hollow-fiber membrane) removes impurities in the feed water, including microorganisms, residual chlorine, and organic matter.
- A high-performance ion-exchange resin column (CPC-S, 4L) provides high-purity water with low conductivity and low TOC levels.
- A filter (0.1μm hollow-fiber membrane) is provided as standard at the water outlet.
- Distilled water storage tank capacity is 30L (WG253), 100L (WG1013), and 10L (WGS201).
- The display panel indicates the replacement timing for consumables.
- The drawer-type water collection stand includes a drainage function, enabling safe water collection.



Specifications

Model		WG253	WG1013	WGS201
Function	Water quality	Ion exchange water	A4	
	Distilled water production	~1.5L/h	~5L/h	~1.5L/h
	Distilled water tank capacity	30L	100L	10L
	Dispenser	○	○	○
7-inch LCD screen		○	○	○
Method / Performance ¹⁾	Water sampling method	Ion exchange → Filtration	Ion exchange → Distillation → Filtration	
	Pure water sampling	Ion exchange water / distilled water		
	Distilled water production	~1.5L/h	~5L/h	~1.5L/h
	Distilled water delivery rate ²⁾	Drip~approx. 2.5L/min (with variable flow rate function)		
Ion exchange water delivery rate ²⁾	~1.0L/min (without variable flow rate function)			
Setting range of production ³⁾	0.01L~tank storage volume / Continuous water sampling			
Configuration	Condenser	Hard glass		
	Heater	Ceramic heater 1.2kW	Ceramic heater 1.9kW×2 pcs.	Ceramic heater 1.2kW
	Pretreatment cartridge	0.1 μm hollow fiber membrane with activated carbon (PWF-1)		
	Ion exchange resin cartridge	CPC-S 4L type, 1 pc. (Activated carbon cartridge)	CPC-S 4L type, 2 pcs. (Activated carbon cartridge)	CPC-S 4L type, 1 pc. (Activated carbon cartridge)
	Final filtration of distilled & ionized water	0.1μm×2 (membrane filter)		
	Leak detection	Forced shutoff of water solenoid valve by leak detection sensor in case of water leakage		
	Distilled water storage tank	Polyethylene tank, 30L	Polyethylene tank, 100L	Polyethylene tank, 10L
	Distilled water UV sterilization	Option		
	Water sampling tray	Push-open type, Load capacity: 10kg, for 5L hand-held beaker	Push-open type, Load capacity: 5kg	
	Multi-purpose distilled water sampling port	For connection of φ8 rigid tube (right side of main unit)		
Standards	Water level detection	Float switch, 5-step detection	Float switch, 5-step detection	Float switch, 4-step detection
	Raw water pressure range	0.05~0.5MPa	0.1~0.5 Mpa	0.05~0.5 Mpa
	Amount of raw water required	~2.0 L/min	~2.6 L/min	~2.0 L/min
	Ambient temperature range	5~35°C		
Power supply (50/60Hz) ⁴⁾	AC110/115/120/220/230/240V, with step-down transformer	AC220/230/240V, with step-down transformer	AC110/115/120/220/230/240V, with step-down transformer	
External dimensions ⁴⁾	W540×D570×H775 mm	W550×D570×H1715 mm	W350×D570×H845 mm	
Weight	Approx. 63kg	Approx. 113 kg	Approx. 54kg	
Display / Setting	Water level display	Digital (7-inch LCD panel)		
	Water quality display	Digital (conductivity / resistivity switching)		
	Other Displays	Notification : Various consumables / Scheduled maintenance Warning : Water cut off / No record of trend data/Power failure / Low distilled water quality Abnormality : Controller / Water leak / Heater overheat, Disconnection / Tank water level gauge / Boiler water level / Boiler water level gauge / Boiler drainage route / Cooling water, Feed water valve / Water quality meter / Water sampling pump / Low flow (ion exchange water) / Water sampling route / UV lamp abnormality / Internal communication		
	Accessories	Water supply hose (2 m) / Water supply hose filter / Connecting hose assembly (2 pcs) / Pretreatment cartridge / Ion exchange resin cartridge (2 pcs) / Air vent filter / Membrane filter (2 pcs) / Filter cover (2 pcs) / Magnetic hook (2 pcs) / Operation manual (operation section, structure section)	Water supply hose (2m) / Water supply hose filter / Connection hose assembly (2 pcs) / Pretreatment cartridge / Ion exchange resin cartridge (2 pcs) / Air vent filter / Membrane filter (2 pcs) / (2 pcs) / Filter cover (2 pcs) / Magnetic hook (2 pcs) / Adjuster clamp (4 pcs) / Operation manual (Operation Section, Structure Section)	Water supply hose (2 m) / Water supply hose filter / Connection hose set / Pretreatment cartridge / Ion exchange resin cartridge / Air vent filter / Membrane filter (2 pcs) / Water inlet cover (2 pcs) / Magnetic hook (2 pcs) / Fall protection fixture with mat (OA 206) / Operation manual (Operation section and structure section)

Touch panel (7-inch)



Magnet-type Dispenser



¹⁾ Performance values are for WG202, WG253, WGS201, and WG206 : Power supply AC 100V, room temperature 23°C ±5°C, humidity 65% RH ±20%. The ambient temperature range of this product is 5 to 35°C. The raw water temperature range is 5 to 30°C. If the raw water temperature is high, the wastewater temperature may be higher. If the raw water temperature is high, the drainage temperature may be high. If the temperature exceeds 60°C, a drainage trap is required. ²⁾ The guaranteed performance range is 0.2 to 0.5MPa of raw water pressure. The amount of water sampled varies depending on changes in the raw water pressure. ³⁾ The accuracy of the quantitative water sampling is about 10%. ⁴⁾ Protrusions are not included. ⁵⁾ Voltage modifications other than the listed specifications are also available. Please contact us for details.

Made in Japan

Flagship Model of the Auto Still Series

This flagship model represents the Auto Still series. Its control panel features a color LCD and a new dispenser, improving ease of use. The display shows water-quality trends, consumable replacement alerts, and illustrated replacement procedures for intuitive operation. The dispenser is designed for accurate dispensing, and its magnetic mount allows flexible positioning on the unit to suit different workflows.

Water purifier (Auto Still) WG1013



【Main specifications】
 Dimensions : W550×D570×H1715mm (not including protruding parts)
 Weight : Approx. 113kg
 Water quality level : A4 (Ion-exchanged water / Distilled water)
 Distilled water production capacity : 5L/h, Tank capacity 100L

Water Purifier (Auto Still) WG253



【Main specifications】
 Dimensions : W540×D570×H775mm (not including protruding parts)
 Weight : Approx. 63kg
 Water quality level : A4 (Ion-exchanged water / Distilled water)
 Distilled water production capacity : 1.5L/h, Tank capacity 30L

Block Diagram

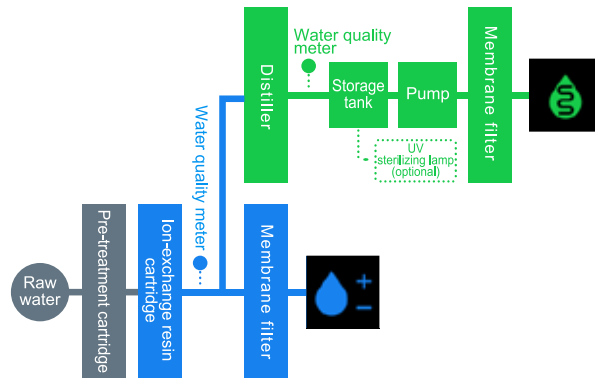

Sterilizers	1
Granulation and Spray Dryers	2
Furnaces	3
Ovens	4
Incubators	5
Plasma Equipment	6
Water Purifiers	7
Baths	8
Water Circulators	9
Rotary Evaporators	10
Stirrers & Shakers	11
Options	12

Slim Design for Installation in Limited Spaces

This model offers the same functions as the WG253, but its space-saving design allows installation in limited sink or laboratory bench space. With a 10L tank capacity, it is ideal for environments with low daily water demand.

Size Comparison with WG253

The main unit depth is 570mm, the same as the previous model. Meanwhile, the front width has been reduced by approximately 35%, making installation easier in limited sink and laboratory bench spaces. In addition, an optional anti-tip bracket is available for added safety.

Front Size Comparison with the WG253 Water Purifier

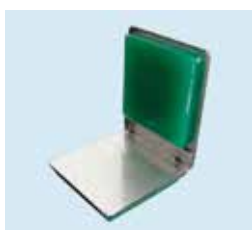

Fall prevention metal fixture with mat (option)



Fall prevention metal fixture (option)

Water Purifier (Auto Still) WGS201



【Main specifications】

Dimensions : W350×D570×H845mm (excluding protruding parts)

Weight : Approx. 54kg

Water quality level : A4 (ion exchanged water/distilled water) distilled water production capacity : 1.5L/h, Tank capacity 10L

Comparison by Daily Distilled Water Usage

If daily usage is low, the space-saving WGS201 is recommended.

Model	Approximate amount of distilled water used (per day)
WGS201	Less than 10L
WGH202, WG253/206	10 to 30L
WG1013	30 to 90L

Block Diagram

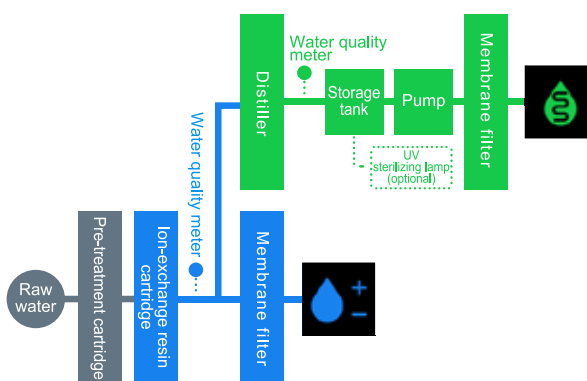

- 1 Sterilizers
- 2 Granulation and Spray Dryers
- 3 Furnaces
- 4 Ovens
- 5 Incubators
- 6 Plasma Equipment
- 7 Water Purifiers
- 8 Baths
- 9 Water Circulators
- 10 Rotary Evaporators
- 11 Stirrers & Shakers
- 12 Options

Water Purifiers | Entry Class

WG206

Made in Japan

Distillation capacity 1.5L/h | Collection method Ion exchange method → Distillation method | Purified water collection Ion-exchange water/Distilled water | Water quality level A4 (Ion-exchange water)/A4 (Distilled water)

Economical model compliant with JIS K 0557 A4 water-quality standard.



Features

- High-purity water is produced through ion exchange → distillation.
- A pretreatment column (activated carbon + 0.1µm hollow-fiber membrane) removes impurities from feed water, including trihalomethanes, residual chlorine, and other contaminants.
- A high-performance ion exchange resin column (CPC-S, 4L) ensures high-purity water with low conductivity and low TOC levels.

Specifications

Model		WG206
Function	Water quality	Ion exchange water A4 Distilled water A4
	Distilled water production	~1.5L/h
	Distilled water tank capacity	20L
Method / Performance ^{*1}	Water sampling method	Ion exchange water Ion exchange → (Option: Filtration) Distilled water Ion exchange → Distillation →(Option: Filtration)
	Pure water sampling	Ion exchange water / distilled water
	Distilled water production	~1.5L/h
	Distilled water delivery rate ^{*2}	~1.5L/min
	Ion exchange water delivery rate ^{*2}	~1.0L/min
	Setting range of production ^{*3}	Continuous water sampling
Configuration	Condenser	Hard glass
	Heater	Ceramic heater 1.2kW
	Pretreatment cartridge	0.1 µm hollow fiber membrane with activated carbon (PWF-1)
	Ion exchange resin cartridge	CPC-S 4L type, 1 pc. (Activated carbon cartridge)
	Final filtration of distilled & ionized water	Membrane filter (option)
	Leak detection	Forced shutoff of water solenoid valve by leak detection sensor in case of water leakage
	Distilled water storage tank	Polyethylene tank, 20L
	Multi-purpose distilled water sampling port	For connection of Φ8 rigid tube (right side of main unit)
	Water level detection	Float switch, 2-step detection
Standards	Raw water pressure range	0.05~0.5 Mpa
	Amount of raw water required	~2.0 L/min
	Ambient temperature range	5~35°C
	Power supply (50/60Hz) ^{*5}	AC110/115/120/220/230/240V, with step-down transformer
	External dimensions ^{*4}	W540×D575×H775 mm
	Weight	Approx. 55kg
Display / Setting	Water level display	Water level indication of communicating tube
	Water quality display	5-step LED display of conductivity (ion-exchanged water)
	Other Displays	Consumables replacement indicator (ion exchange resin cartridge)
	Accessories	Water supply hose (2m) / Water supply hose filter / Connecting hose assembly / Pretreatment cartridge / Ion exchange resin cartridge / Operation manual

*1 Performance values are for WGH 202, WG253, WGS201, and WG206 : Power supply AC 100V, room temperature 23°C ±5°C, humidity 65% RH±20%. WG1013 : Power supply AC 200V, room temperature 23°C ±5°C, humidity 65% RH ±20%. The ambient temperature range of this product is 5 to 35°C. The raw water temperature range is 5 to 30°C. If the raw water temperature is high, the wastewater temperature may be higher. If the raw water temperature is high, the drainage temperature may be high. If the temperature exceeds 60°C, a drainage trap is required. *2 The guaranteed performance range is 0.2 to 0.5MPa of raw water pressure. The amount of water sampled varies depending on changes in the raw water pressure. *3 The accuracy of the quantitative water sampling is about 10%. *4 Protrusions are not included. *5 Voltage modifications other than the listed specifications are also available. Please contact us for details.

Sterilizers	1
Granulation and Spray Dryers	2
Furnaces	3
Ovens	4
Incubators	5
Plasma Equipment	6
Water Purifiers	7
Baths	8
Water Circulators	9
Rotary Evaporators	10
Stirrers & Shakers	11
Options	12

Standard Model with the Same Water Quality as WG253 and WG1013

Although this model does not include an LCD touch panel or dispenser, it delivers A4-grade pure water (both distilled and ion exchanged), equivalent in quality to the WG253/WG1013.

In addition to warning displays and alarm functions for consumable replacement timing, the unit is equipped with comprehensive safety features for water leaks, water outages, overheating, and more, ensuring safe operation.

This standard model maintains water quality while minimizing consumable use and overall cost.

Equipped with Automatic Boiler Drainage

During prolonged continuous distillation, non-volatile impurities can concentrate in the boiler, which may affect water quality.

To help maintain stable water quality, the unit automatically drains the boiler every 5 hours.

Controller

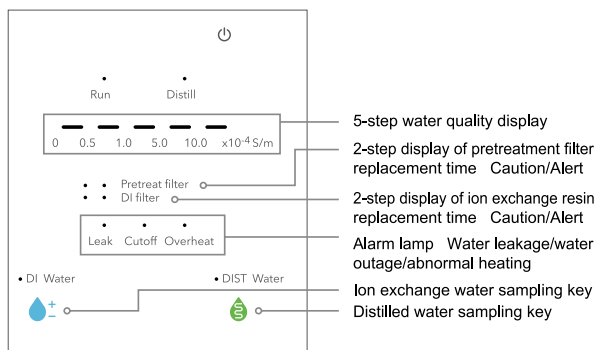

For daily operation, simply turn on the power switch and press the ion-exchanged water or distilled water dispensing key. This simple operation lets you obtain A4-grade pure water anytime.

Water Purifier (Auto Still) WG206



【Main specifications】

Dimensions : W540×D575×H775mm (excluding protruding parts)

Weight : Approx. 55kg

Water quality level : A4 (Ion exchanged water / Distilled water) Distilled water production capacity : 1.5L/h, Tank capacity 20L

Block Diagram

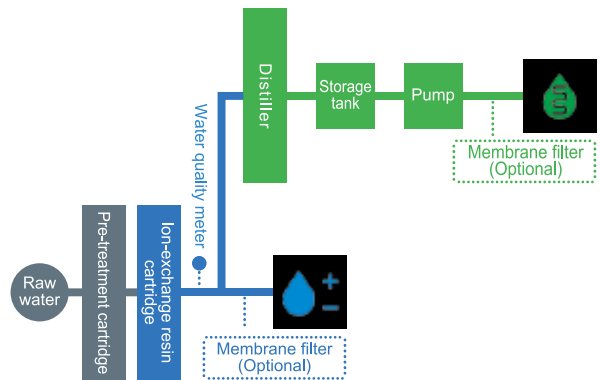

Highest-grade A4 pure water (compliant with JIS K0557).

Water quality analysis results (WG253/1013/WGS201/WG206)

Item	Standard JIS K0557 Standard A4	Measured value												
		WG253			WG1013			WGS201			WG206			
		Ion-exchanged water	Distilled water	Classification	Ion-exchanged water	Distilled water	Classification	Ion-exchanged water	Distilled water	Classification	Ion-exchanged water	Distilled water	Classification	
Electrical conductivity (mS/m)	≦0.1	0.0055	0.079	A4	0.0055	0.065	A4	0.0055	0.083	A4	0.0055	0.079	A4	
Total organic carbon (TOC) (μg/L)	≦50	11.4	8.4	A4	12.6	8.4	A4	11.8	10.8	A4	11.4	8.4	A4	
Zinc (μg/L)	≦0.1	<0.1	<0.1	A4	<0.1	<0.1	A4	<0.1	<0.1	A4	<0.1	<0.1	A4	
Silica (μg/L)	≦2.5	<0.1	1.8	A4	<0.1	2.1	A4	<0.1	1.3	A4	<0.1	1.8	A4	
Chloride ion (μg/L)	≦1	<0.1	<0.1	A4	<0.1	<0.1	A4	<0.1	<0.1	A4	<0.1	<0.1	A4	
Sulfate ion (μg/L)	≦1	<0.1	<0.1	A4	<0.1	<0.1	A4	<0.1	<0.1	A4	<0.1	<0.1	A4	
Total water quality level	A4	A4						A4	A4					

*Raw water: Tap water in Tokyo. Values may vary depending on raw water quality and other factors.

Sterilizers	1
Granulation and Spray Dryers	2
Furnaces	3
Ovens	4
Incubators	5
Plasma Equipment	6
Water Purifiers	7
Baths	8
Water Circulators	9
Rotary Evaporators	10
Stirrers & Shakers	11
Options	12

Optional Items

Item Name	Product code	Model	WGH 202	WG 253	WG 1013	WGS 201	WG 206	Remarks
Stand	281333	OA097	○	○		○	○	W540×D660×H800mm with caster and adjuster
Water sampling hose unit	281336	OA100					○	Membrane filter, silicone hose 2m, with magnetic hook
Faucet connector for water supply hose	281337	OA101	○	○	○	○	○	Raw water side: G1/2 male or whitworth screw thread W26-20
Water tap	281338	OA102	○	○	○	○	○	Raw water side: G 1/2 male or Rc 1/2 female
Water tap (with pressure reducing valve)	281339	OA103	○	○	○	○	○	Raw water side: G 1/2 male or Rc 1/2 female
Drainage trap	281340	OA104	○	○	○	○	○	Used when drain water temperature is high
Water supply extension hose (1m)	281341	OA105	○	○	○	○	○	1m extension of standard 2m water supply hose
Drainage hose (3m)	281342	OA106	○	○	○	○	○	Remove and exchange the standard 2m hose.
Foot switch	281343	OA107	○	○	○	○		Cord length 5m
Water sampling port cover	281344	OA108	Standard	Standard	Standard	Standard	○	-
Shower nozzle	281345	OA109	○	○	○	○		-
Extension hose for ion exchange resin	281346	OA110		○			○	Hose for CPC-S expansion
Pure water delivery unit	253135	PW200	○	○	○	○	○	Water supply pump for distilled water
Pure line	253669	WL100H	○	○	○	○	○	Connection part for WL100 + WG 205 / 252 / 1012
Filter housing	281347	OA111	○	○	○	○	○	For filters to be installed on the primary side of WL100
Filter stand	281348	OA112	○	○	○	○	○	Self-supporting stand, up to 2 housings can be mounted
External alarm output *	281351	OA113		○				Signal output in the event of notification, alarm, or abnormality (installed when ordered)
External alarm output *	281352	OA114			○			
External alarm output *	281629	OA203				○		Output signals externally in the event of consumable notification, alarm, or abnormality
External alarm output *	281645	OA217	○					
Dispenser extension hose for ion exchange water	281630	OA204	○	○	○	○		Extends the dispenser hose for collecting ion exchange water to approximately 3m outside the machine, reducing the amount of ion exchange water collected to approximately 0.9 L/min
Dispenser extension hose for distilled water	281631	OA205		○	○	○		Extends the dispenser hose for collecting distilled water to approximately 3m outside the equipment, reducing the amount of distilled water collected to approx. 2.2 L/min.
Dispenser extension hose for distilled ultra-pure water *	281644	OA216	○					Extend the dispenser hose for collecting distilled ultrapure water to approximately 3m outside the equipment. Reduction of distilled ultrapure water collected to approx. 2.2 L/min.
Fall prevention metal fixture with mat	281632	OA206	○	○		Standard		Fall prevention L-metal fittings are attached to the side of the equipment and secured with adhesive mats (standard accessory)
Fall prevention metal fixture	281633	OA207				○		Fix the front of the equipment to the top board (front part) of the laboratory bench.
Fall prevention plate (A)	281642	OA214				○		Mounted on the bottom of the equipment and fixed to the sink with adhesive mats. for 600mm depth (Trespa top board)
Fall prevention plate (B)	281643	OA215				○		Mounted on the bottom of the equipment and fixed to the sink with adhesive mats. for 750mm depth (Trespa top board)
Water sampling stand	281637	OA208	○	○	○	○	○	Stand to secure the dispenser at a position away from the equipment. W410×D420×H620mm Weight : approx. 8kg
Water leak detection and water supply shutoff unit	254198	Y-MGB101	○	○	○	○	○	Line sensors wired around the equipment detect leaks and shut off the water supply. Used by attaching a motor valve to the primary side of raw water.
Sterilization lamp *	281626	OA200	Standard	○				Prevents bacterial growth in distilled water tank. Sterilization light built-in set, Mercury-free (Standard equipment)
Sterilization lamp *	281627	OA201			○			Prevents bacterial growth in distilled water tank. Sterilization light built-in set, Mercury-free
Sterilization lamp *	281628	OA202				○		
UV lamp for sterilization lamp (for OA200 / 202)	281636	OA209	○	○	○	○		Prevents bacterial growth in distilled water tank. Replacement LED Lamp
UV lamp for sterilization lamp (for OA201)	281646	OA218			○			

* Please specify when ordering main unit.

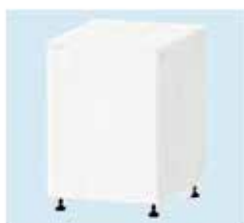

Stand



Water sampling hose unit



Faucet connector for water supply hose



Water tap (with pressure reducing valve)



Drainage trap (example of installation)



Water supply extension hose (1m)



Water supply extension hose (1m)



Foot switch



Water sampling port cover



Shower nozzle



Pure water delivery unit



Pure line



Filter Housing / Stand

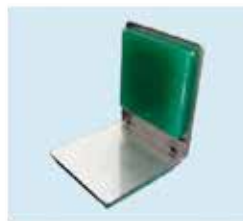

Fall prevention metal fixture with mat



Fall prevention metal fixture



Water sampling stand



UV lamp for sterilization lamp

- 1 Sterilizers
- 2 Granulation and Spray Dryers
- 3 Furnaces
- 4 Ovens
- 5 Incubators
- 6 Plasma Equipment
- 7 Water Purifiers**
- 8 Baths
- 9 Water Circulators
- 10 Rotary Evaporators
- 11 Stirrers & Shakers
- 12 Options

Consumables

Item Name	Product code	Model	WGH 202	WG 253	WG 1013	WGS 201	WG 206
Membrane filter (set of 2)	9020010004	MFRL727	○	○	○	○	○
Pretreatment cartridge	253099	PWF-1	○	○	○	○	○
Ion exchange resin cartridge	253080	CPC-S	○	○	○	○	○
Air filter	9020020001	AVF-1(4210)					○
Air vent filter	LT00040430	YAVF-1	○	○	○	○	
Pre-filter (wind cartridges)	9020036001	SWPP-010-1	○	○	○	○	○
Activated carbon filter	9020026002	YAC-250	○	○	○	○	○
High-purity cartridge	253259	CPC-H2	○				



Membrane filter



Pretreatment cartridge



Ion exchange resin cartridge



Air vent filter