

Solvent Recovery Unit GAS410

- First edition -

● Thank you for purchasing "Solvent Recovery Unit GAS410" of Yamato Scientific Co., Ltd.

● To use this unit properly, read this "Instruction Manual" thoroughly before using this unit.

Keep this instruction manual around this unit for referring at anytime.

 : WARNING!:

Carefully read and thoroughly understand the important warning items described in this manual before using this unit.

1. Safety precautions.....	1
Explanation of pictograms.....	1
List of symbols	2
Warning-Cautions.....	3
2. Before using this unit.....	5
Precautions when installing the unit.....	5
3. Names and functions of parts	8
Main unit.....	8
Internal mechanism.....	9
Operation panel.....	10
4. Operating procedures	11
Preparations.....	11
Preparations (ADL311S+GAS410)	12
Preparations (GB210A+GAS410)	14
Operating method	16
Related Figure between Blower and Temperature/Circulating Air Quantity (Reference)	22
5. Handling Precautions.....	23
About applicable organic solvents.....	24
Corrosion resistance table.....	26
Piping system diagram.....	27
List of materials.....	28
Precautions during operation	29
6. Maintenance Method	31
Daily Inspection and Maintenance	31
7. Long storage and disposal	34
When not using this unit for long term / When disposing.....	34
Matters to consider when disposing of the unit.....	34
8. When a trouble occurs	35
Safety unit and error indications.....	35
Safety unit and error indications.....	36
Confirmation and language select for the manual.....	37
Trouble Shooting.....	39
9. After Service and Warranty	42
When requesting a repair.....	42
10. Specifications	43
11. Wiring diagram.....	44
12. Replacement parts table	45
13. List of Dangerous Substances	47

1. Safety precautions

Explanation of pictograms

About pictograms

A variety of pictograms are indicated in this operating instruction and on products for safe operation. Possible results from improper operation ignoring them are as follows.

Be sure to fully understand the descriptions below before proceeding to the text.

 **Warning** Indicates a situation which may result in death or serious injury (Note 1.)

 **Caution** Indicates a situation which may result in minor injury (Note 2) and property damages (Note 3.)

(Note 1) Serious injury means a wound, an electrical shock, a bone fracture or intoxication that may leave after effects or require hospitalization or outpatient visits for a long time.

(Note 2) Minor injury means a wound or an electrical shock that does not require hospitalization or outpatient visits for a long time.

(Note 3) Property damage means damage to facilities, devices and buildings or other properties.

Meanings of pictograms



This pictogram indicates a matter that encourages the user to adhere to warning ("caution" included).
Specific description of warning is indicated near this pictogram.



This pictogram indicates prohibitions
Specific prohibition is indicated near this pictogram.



This pictogram indicates matters that the user must perform
Specific instruction is indicated near this pictogram.

1. Safety precautions

List of symbols

Warning



General warnings



Danger!: High voltage



Danger!: High temperature



Danger!: Moving part



Danger!: Hazard of explosion

Caution



General cautions



Electrical shock!



Burning!



Caution for no liquid heating!



Caution for water leak!



For water only



Poisonous material

Prohibitions



General bans



Fire ban



Do not disassemble



Do not touch

Compulsions



General compulsions



Connect ground wire



Install levelly



Pull out the power plug



Regular inspection

1. Safety precautions

Warning · Cautions

Warning



Do not use this unit in an area where there is flammable or explosive gas

Never use this unit in an area where there is flammable or explosive gas. This unit is not explosion-proof. Always try to assure sufficient ventilation in the room and take extreme care so that the atmosphere will not reach the explosive limit concentration. See "13. List of Dangerous Substances" on P. 47 for explosive or flammable gases.



Always ground this unit

Always ground this unit on the power equipment side in order to avoid electrical shock due to a power surge.



Apply the source of rated power or more

Be sure to apply the source of rated power or more. Applying non-rated voltage or non-rated power supply may cause the fire or electric shock.



Prohibition of use for error

If a smoke or abnormal smell may be occurred, turn off the power switch of the main unit immediately, and turn off the original power source, and finally contact to either the dealer you purchased this unit or our sales office. Leaving the failure may cause the fire or electric shock. Since the repairing of this unit is dangerous for non-specified service person, never repair the unit by the customer himself.



Do not use the power cord if it is bundled or tangled

Do not use the power cord if it is bundled or tangled. If it is used in this manner, it can overheat and fire may be caused.



Do not damage power cord

Do not damage power cord by bending, pulling, or twisting forcedly. It may cause the fire or electric shock. Besides, operating the unit with the something put on the cord may cause overheat, and result in fire.



Never try to touch a hot part.

Some parts of the unit are hot during and immediately after operation. Take special care for possible burning.



Never try to disassemble or alter the unit.

Never try to disassemble or alter the unit. A malfunction, a fire or an electrical shock may result.

1. Safety precautions

Warning · Cautions

Caution

During a thunder storm

During a thunderstorm, turn off the power key immediately, then turn off the circuit breaker and the main power. If this procedure is not followed, fire or electrical shock may be caused.

If the electric failure shall be occurred,

When power is shut off due to turning the ELB "OFF" or a power failure during GB210A/ADL311S operation (while the blower is in operation or liquid is being sent), the mode will return to ① or ② after recovery.

- ① The mode will return to the initial state when the inlet temperature is 60°C or less or the outlet temperature is 50°C or less.
- ② When the temperature inside the path is high, the unit will continue operation until the inlet temperature drops to 60°C or less or the outlet temperature drops to 50°C or less while only the blower returns.

Do not perform unattended operation during activating the unit

Do not perform unattended operation during activating the unit. Since the unit is in idling status and the nozzle is blocked or after the operation using sample, the temperature around outlet is increased and the remaining sample is flown from the sample tube disconnected from the unit, and this failure may cause the indeterminism accident.

Any people other than the qualified personnel shall never attempt to operate the unit.

Take sufficient care for the control of the unit so that any people other than the qualified personnel shall never have a chance to operate the unit.

Always monitor and check the oxygen concentration.

Always monitor the oxygen concentration in the unit to assure safety.

Take care when opening the unit.

Be sure to confirm that the oxygen concentration has returned to 21% and avoid putting your face close to the exhaust port carelessly when opening the unit.

Take care for solvents you are going to use.

The unit has been designed to use isopropyl alcohol and ethanol. Service lives of a filter element or packing may change depending on the type of solvent used. When leakage of gas or other troubles occurs inside the unit, immediately replace the defective part with a new one. Check whether a solvent can be used or not in the "About the applicable solvents" in the section 5. Handling precautions.

Take care for the use of water based solvents.

When you are going to use a water based solvent, remove the GB210A and use ADL311S or GA310 alone. See "Restrictions by the melting point" in the section 5. Handling precautions (P.24).

2. Before using this unit

Precautions when installing the unit

Warning

1. Always ground this unit



• Be sure to connect the earth wire (the green cable of power cord) to the grounding conductor or ground terminal to prevent accidents caused by electric leakage.



• This unit requires a single phase 220V system power supply (also supports AC200V or AC240V by selecting either of it) (See page 11 (1)) Ask the nearest electrical contractor for the power including the connecting work. The setting (connecting) work is performed following the related electrical equipment technical standard published by the corresponding country to be used this unit.

- Do not connect the earth wire to gas or water pipes. If not, fire disaster may be caused.
- Do not connect the earth wire to the ground for telephone wire or lightning conductor. If not, fire disaster or electric shock may be caused.

Rounded terminal for M4

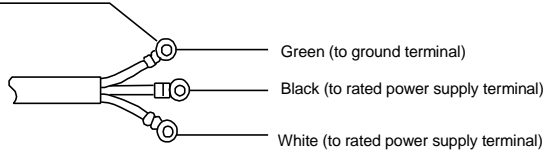

- The power plug is not attached as standard component. Connect the earth correctly adjusting the type of the power equipment of the user.

2. Pay attention to the color of each core wire when connecting the power cord



Be sure to check that the breaker on the power source equipment side is turned "OFF" when connecting power cord without fail. Note that this unit does not attach the power plug as standard component. Select the appropriate power plug and terminal matching to the power capacity of the power source equipment to be connected, and connect them.

Core Wire Color	In-house Wiring
Black	Voltage Side
White	Voltage Side
Green	Ground Side

3. Choose a proper place for installation



Do not install this unit in a place where:

- Rough or dirty surface.
- Flammable gas or corrosive gas is generated.
- Ambient temperature below 5°C or above 30°C.
- Ambient temperature fluctuates violently.
- There is direct sunlight.
- There is excessive humidity and dust.
- There is a constant vibration.
- Place where the water is easy-to-be splashed.



Install this unit on a stable place with the space as shown below.

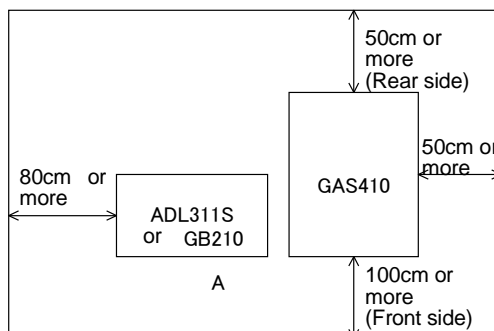



Before using this unit

Precautions when installing the unit

Warning

4. Do not use this unit in an area where there is flammable or explosive gas

 Never use this unit in an area where there is flammable or explosive gas. This unit is not explosion-proof. An arc may be generated when the power switch is turned ON or OFF, and fire/explosion may result.

 Refer to page 47 "13. List of Dangerous Substances".

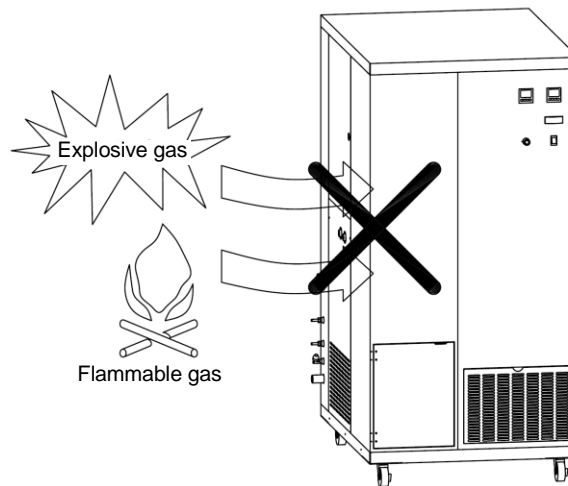

5. Do not use explosive or flammable substances

 Take extreme care for use of an explosive or a flammable solvent. Such a solvent may cause an explosion or a fire.

Check whether a solvent can be used or not in the "About the applicable solvents" in the section 5. Handling precautions (P.24).

Always monitor the oxygen concentration in the unit during operation to assure safety.

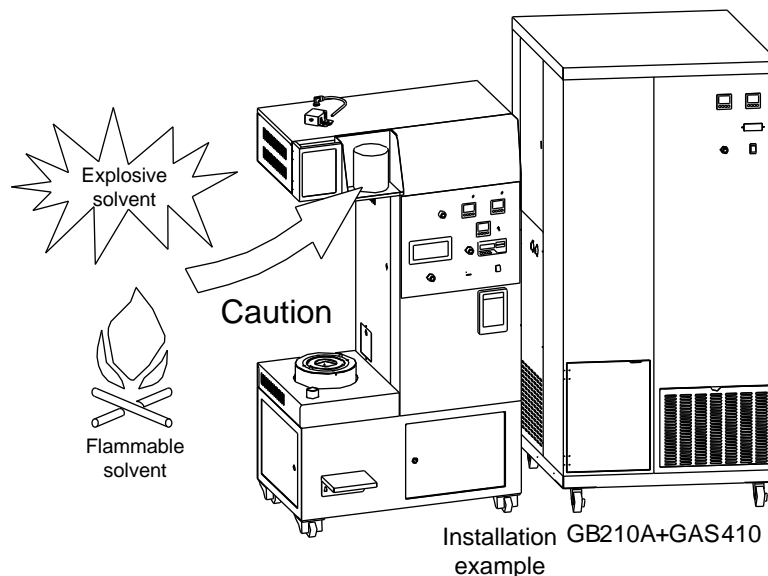

2. Before using this unit

Precautions when installing the unit

Warning

6. Do not modify



Modification of this unit is strictly prohibited. This could cause a failure.

Modification

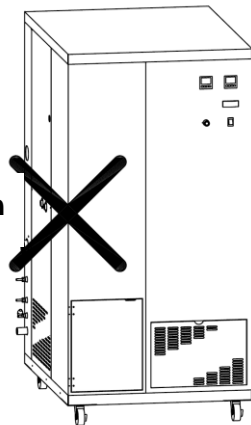

7. Do not topple or tilt this unit



Set this unit to the flattest place. Setting this unit on rough or slope place could cause the vibration or noise, or cause the unrespectable trouble or malfunction.

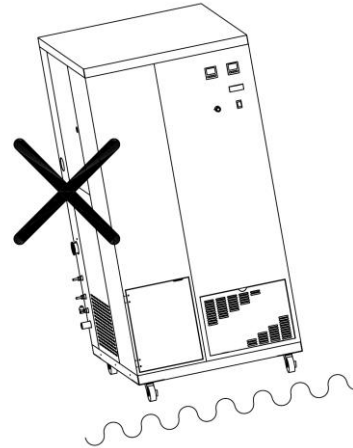

8. Use specified receptacle for power source



Choose a correct power distribution board or receptacle that meets the unit's rated electric capacity.

Electric capacity: single phase 200V-240V~ 5-6A

The unit supports any power supply in the range of AC200V to AC240V. Confirm the current value at a specific voltage and securely connect the power cord to a power supply that meets the specified voltage and current.

There could be the case that the unit does not run even after turning ON the power. Inspect whether the voltage of the main power is lowered than the specified value, or whether other device(s) uses the same power line of this unit. If the phenomena might be found, change the power line of this unit to the other power line.

For connecting of the device to the power source, ask the dealer that you purchased this unit from or an electrical contractor for safe.

9. Handling of power code



Do not entangle the power cord. This will cause overheating and possibly a fire.

Do not bend or twist the power cord, or apply excessive tension to it. This may cause a fire and electrical shock.

Do not lay the power cord under a desk or chair, and do not allow it to be pinched in order to prevent it from being damaged and to avoid a fire or electrical shock.

Keep the power cord away from any heating equipment such as a room heater. The cord's insulation may melt and cause a fire or electrical shock.



If the power cord becomes damaged (wiring exposed, breakage, etc.), immediately turn off the power at the rear of this unit and shut off the main supply power. Then contact your nearest dealer for replacement of the power cord. Leaving it may cause a fire or electrical shock.

Connect the power plug to the receptacle which is supplied appropriate power and voltage.

3. Names and functions of parts

Main unit

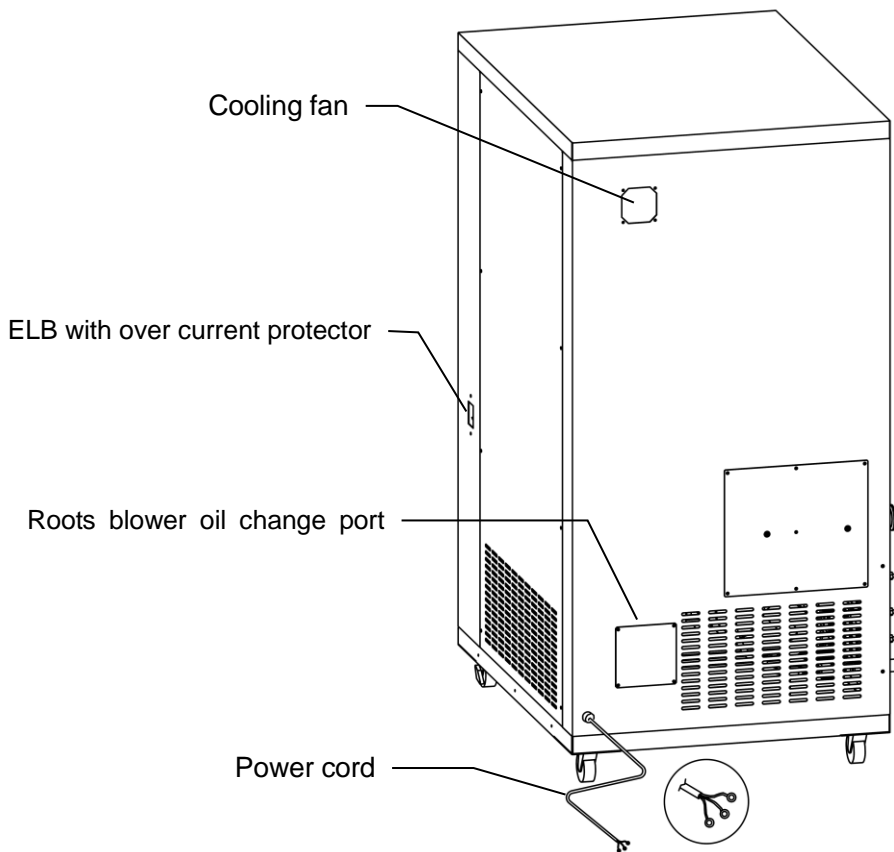
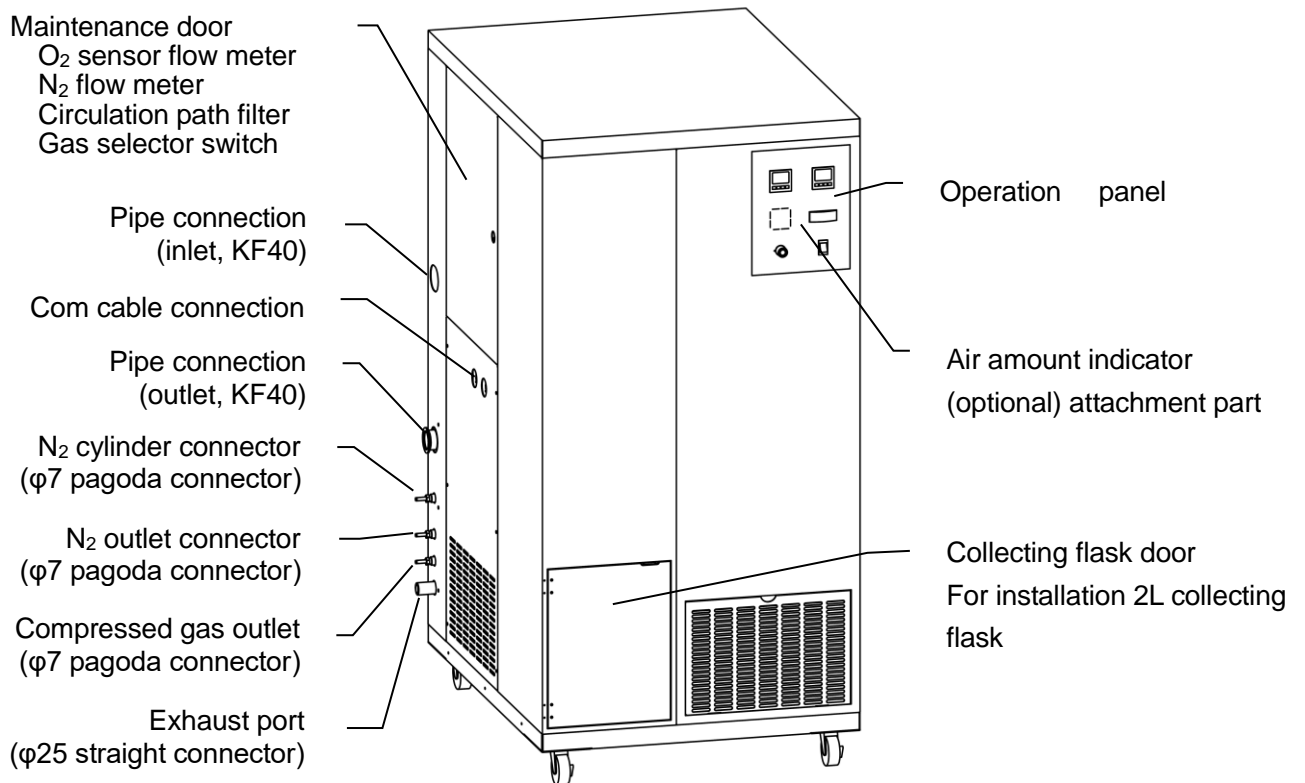

3. Names and functions of parts

Internal mechanism

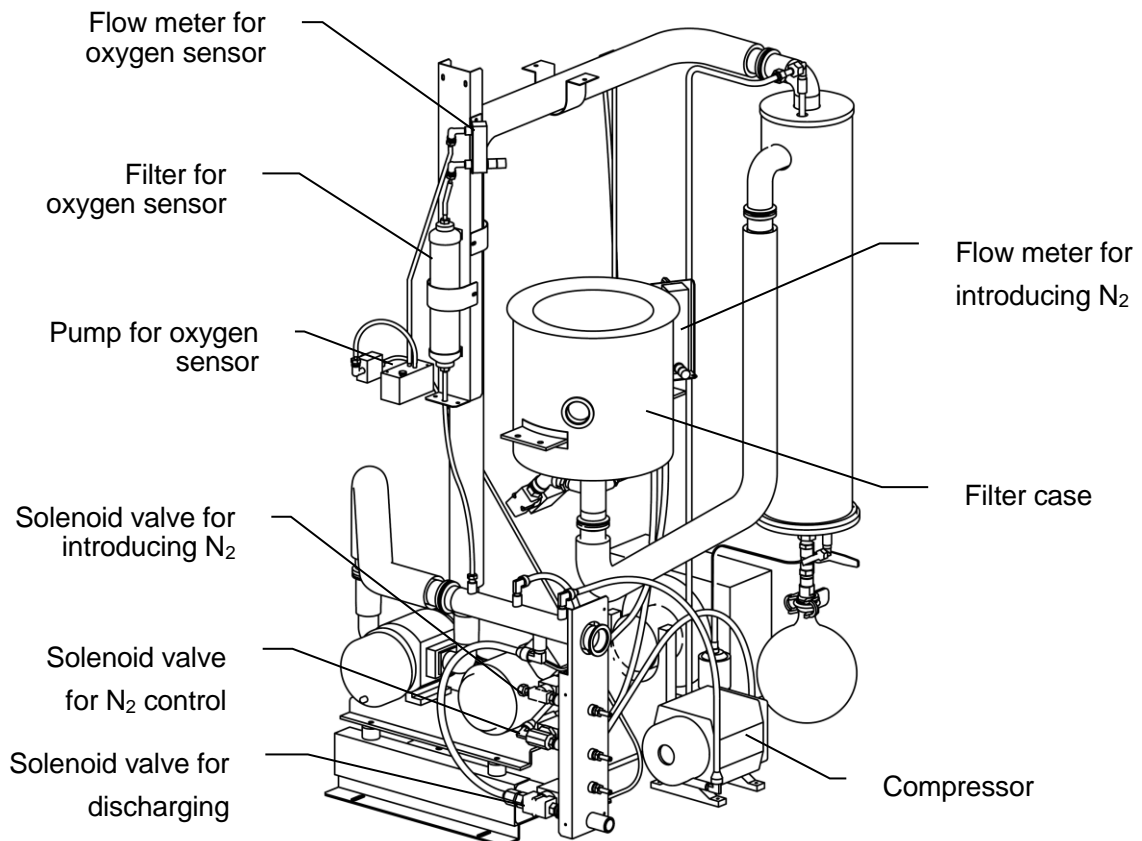
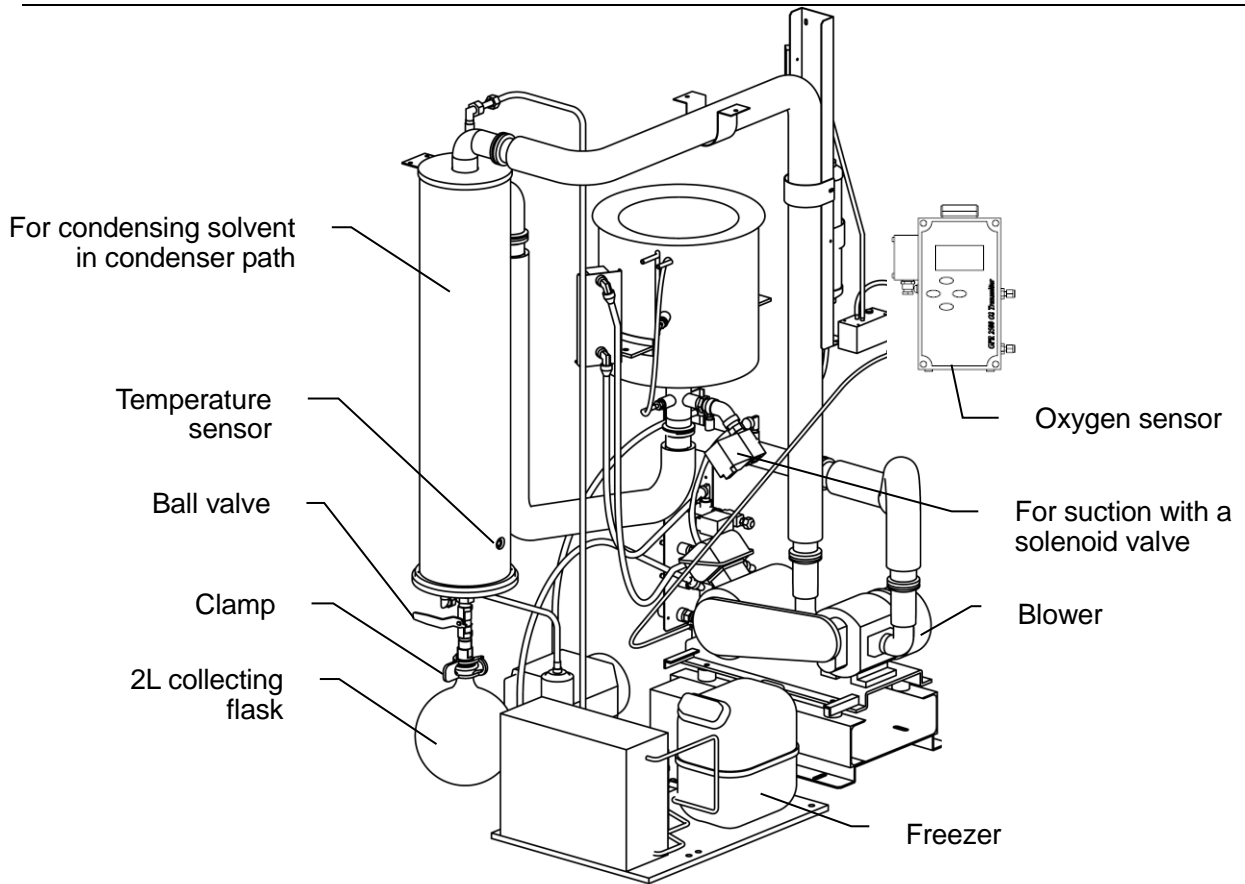

3.Names of parts and their function

Operation panel

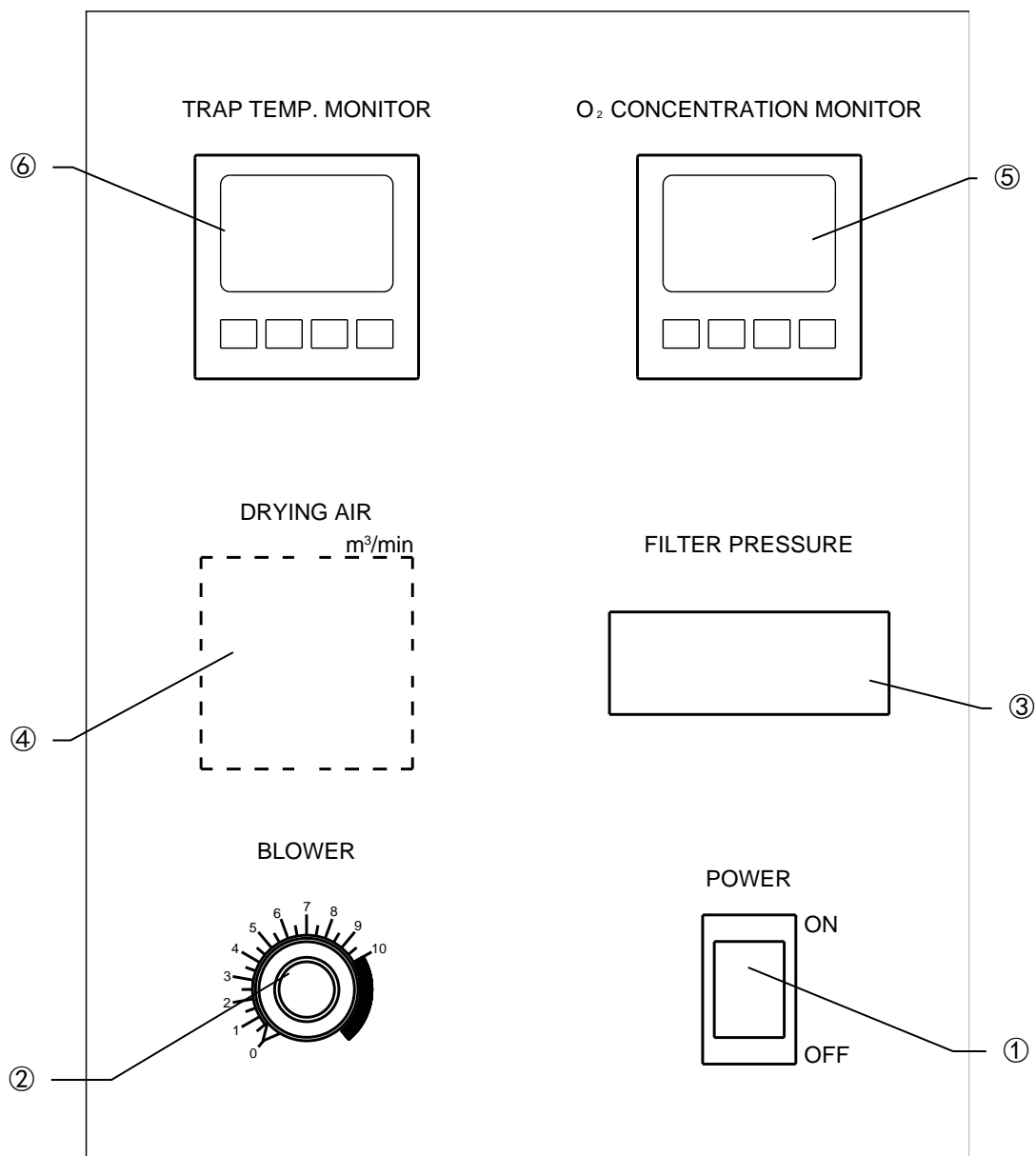

No.	Name	Operation/action
①	Power switch	This is used to turn power ON/OFF.
②	Blower control dial	This is used to set an air amount.
③	Filter differential pressure monitor	Displays differential pressure between the inlet and outlet of the filter to check the filter status.
④	Air amount meter monitor installation port (Air amount meter and monitor are optional)	This port is used for installing optional parts for the air amount meter.
⑤	Oxygen concentration display monitor	This displays oxygen concentration in piping paths.
⑥	Cooling trap temperature monitor	This monitor displays the temperature in the cooling trap for condensing solvents.

4. Operating procedures

Preparations

(1) Connecting the power cord

First check that the switches of the control assembly and the ELB are OFF and then connect the power cord securely to the power supply meeting the specified voltage and current.

(2) Connecting an earth

The power cord of this unit is an earthed 3-core captive cable (VCT) that integrates an earth wire and you must earth the green wire.

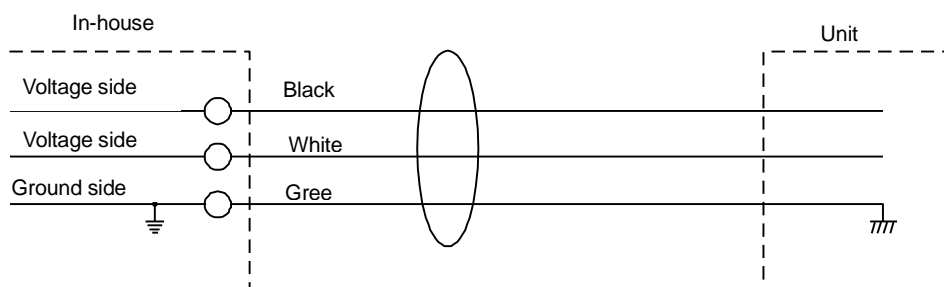

(3) Connecting the exhaust duct

AIR IN operation during operation finishing process will discharge organic solvents, hot air, and fine particles at the exhaust port out of the pipe path. Connect the supplied discharge duct to the discharge port and discharge to external using, for example, a draft chamber. Avoid looking into the discharge port or discharge directly to external, which might pose a danger. The discharge port is located at the lowest part at the left side of the main unit.

(4) Connecting the collecting flask

Push the collecting flask against the connecting port below the ball valve and then fix it.

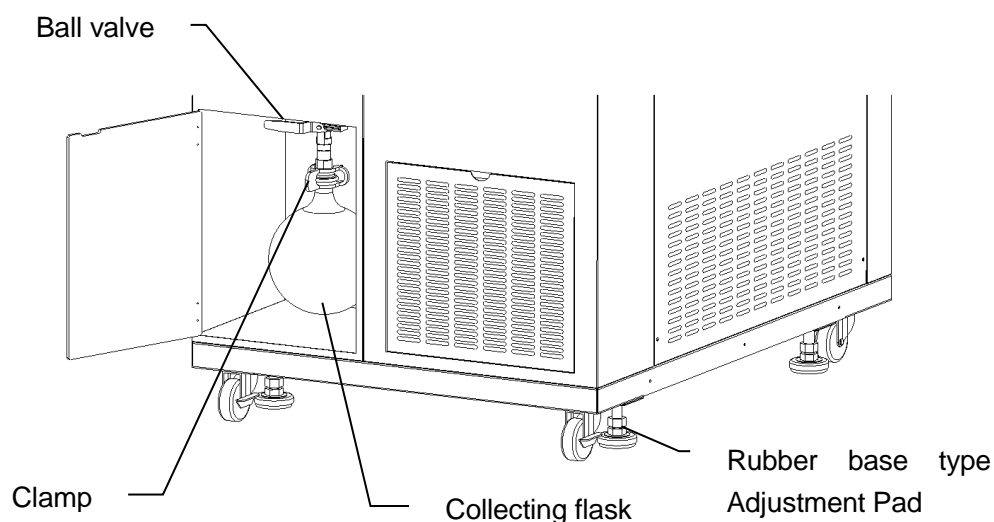

4. Operating procedures

Preparations (ADL311S+GAS410)

- (1) The leg of ADL311S becomes the caster specifications, but I install a footstool (an option) for exclusive use of ADL311 in an operation position lowering by all means, and can put height together when I am connected to GAS410.

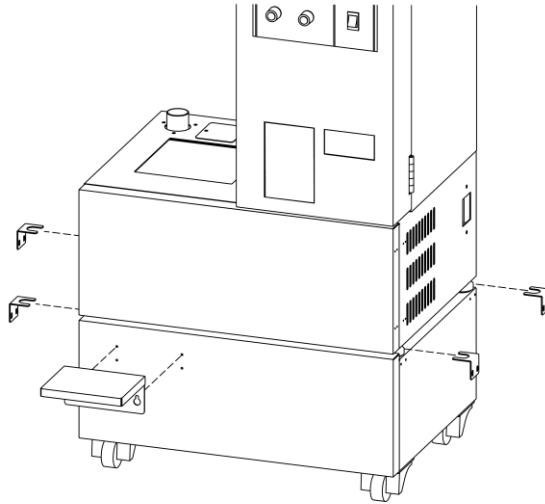

- ※ The footstool (an option) for exclusive use of ADL311 becomes the remodeling at the time of the factory shipment.

- (2) Remove the suction filter and the blind plate.

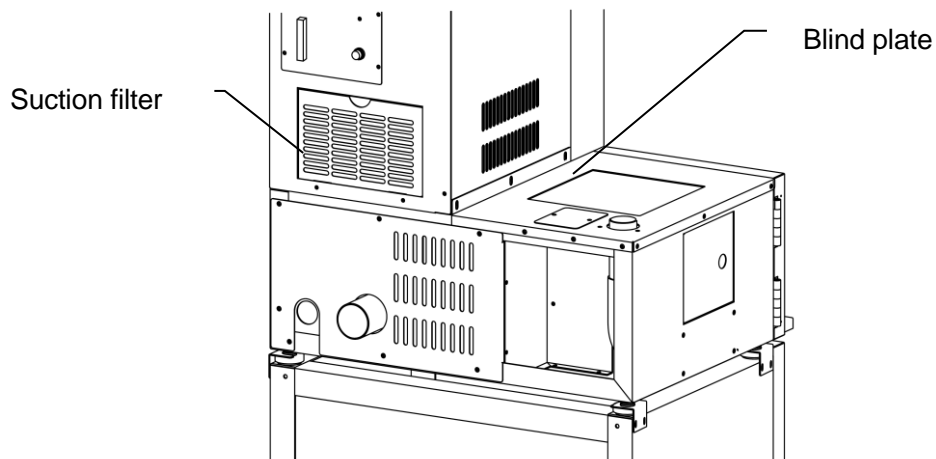

4. Operating procedures

Preparations (ADL311S+GAS410)

- (3) Install the included connecting tube with M4×10 truss screws.

Connect the hose from the outlet on the cyclone to the connecting tube you have installed.

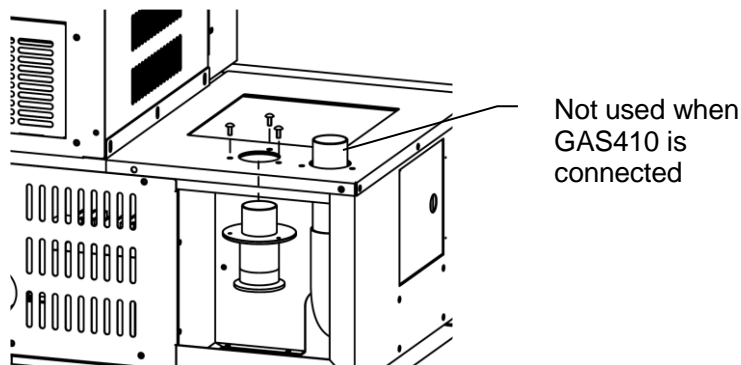

- (4) Connect the ADL311S and the GAS410.

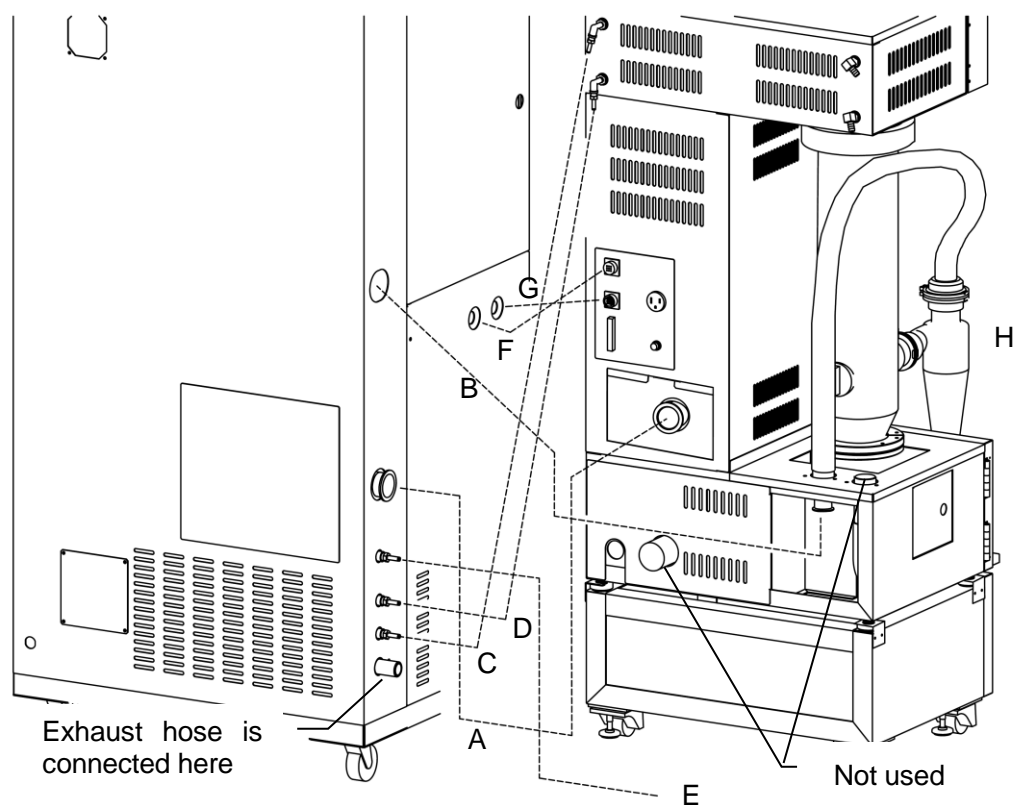

- A: Connect the flexible duct into the heater cylinder inlet to the duct connecting (outlet) port of GAS410.
Put an O-ring and securely fix using a clamp for installation.
- B: Connect the flexible duct into the connecting tube to the duct connecting (inlet) port of GAS410.
Put an O-ring and securely fix using a clamp for installation.
- C: Connect a Fluororubber tube (milky white) and fix it using a wire clamp.
- D: Connect a tetrone braided hose and fix it using a wire clamp.
- E: Connect a tetrone braided hose to the N₂ gas supply unit and fix it using a wire clamp.
- F: Connect an interface cable.
- G: Connect an interface cable.
- H: Set GF300 to the main unit according to the operation manual of ADL311S. Note, however, the outlet of the cyclone for the connecting hose.

4. Operating procedures

Preparations (GB210A+GAS410)

- (1) Open the right side door of GB210A, install a blind plate to the upper position of the connecting port and remove a set of filter installation parts from the lower position of the connecting port.

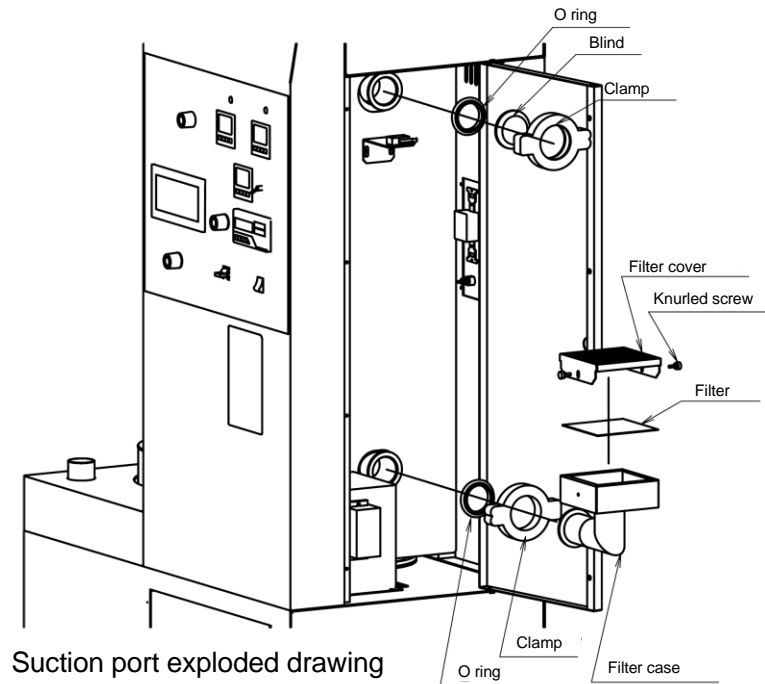

- (2) Connect the supplied connecting tube using M4×10 truss screws.

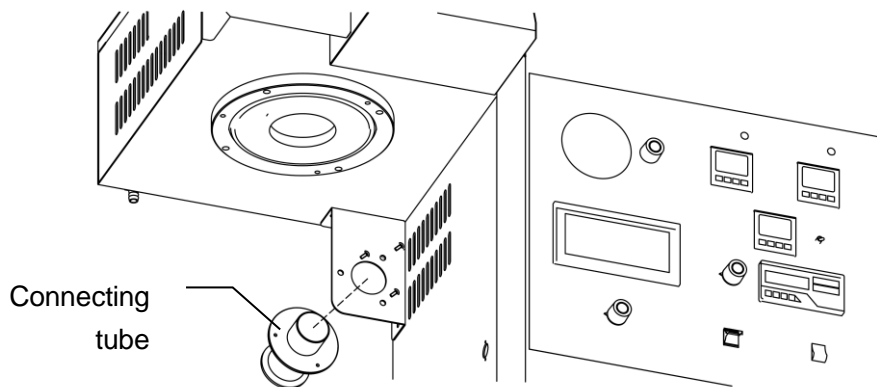

4. Operating procedures

Preparations (GB210A+GAS410)

(3) Connect between GB210A and GAS410.

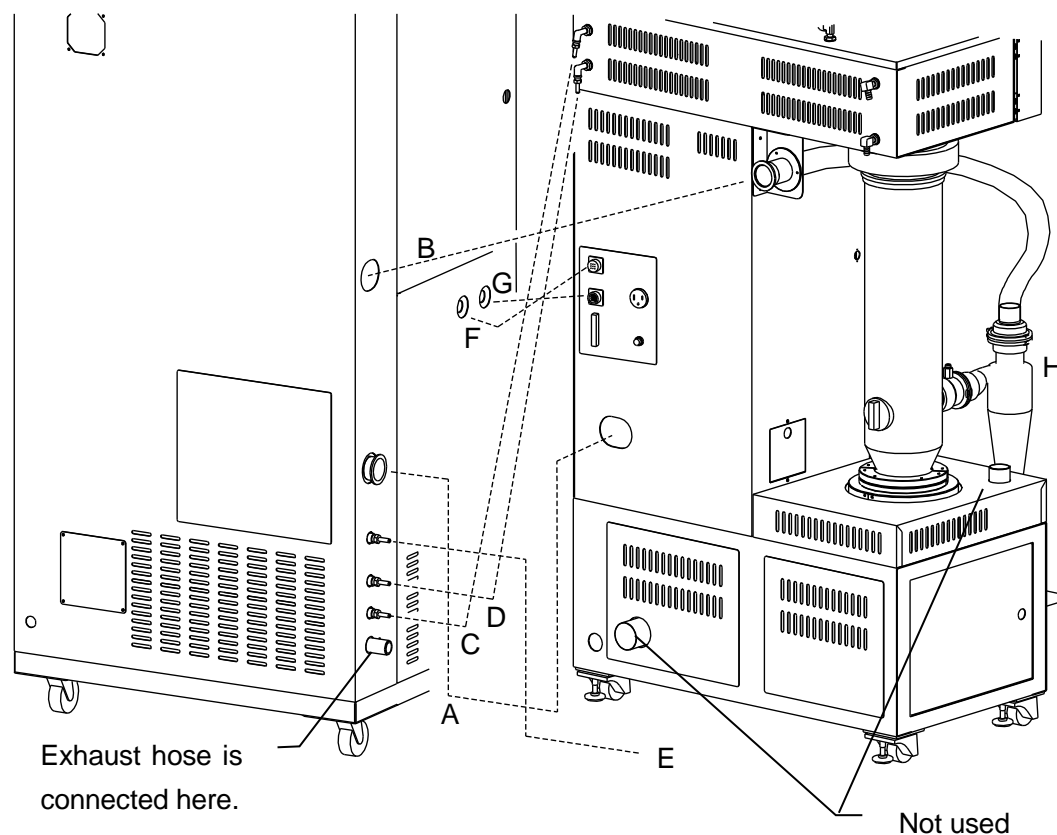

- A: Connect the flexible duct into the inlet below the heater cylinder to the duct connecting (outlet) port of GAS410.
Put an O-ring and securely fix using a clamp for installation.
- B: Connect the flexible duct into the connecting tube to the duct connecting (inlet) port of GAS410.
Put an O-ring and securely fix using a clamp for installation.
- C: Connect a Fluororubber tube (milky white) and fix it using a wire clamp.
- D: Connect a tetrone braided hose and fix it using a wire clamp.
- E: Connect a tetrone braided hose to the N₂ gas supply unit and fix it using a wire clamp.
- F: Connect an interface cable.
- G: Connect an interface cable.
- H: Set GF300 to the main unit according to the operation manual of GB210A. Note, however, the outlet of the cyclone for the connecting hose. (Connect to the connecting tube.)

4. Operating procedures

Operating method

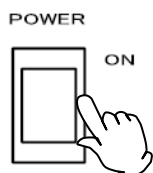
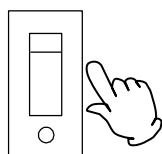

KEY PANEL

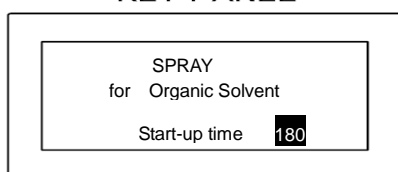

KEY PANEL

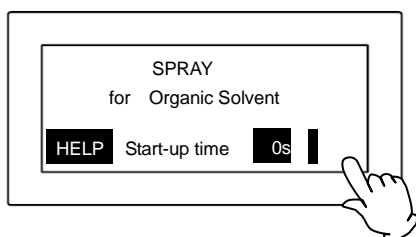

KEY PANEL

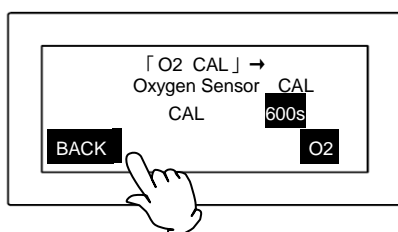

KEY PANEL

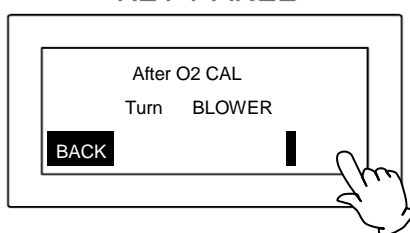

- (1) Turn the ELB on the right side of the main unit ON and then, turn the **power switch** on the operation panel of the main unit ON.

Temperature controllers, indication lamps, and the key panel will be displayed.

※Perform operation both for the main unit (ADL311S or GB210A) and GAS410. Make sure that the indication lamp is lit as SPRAY DRY for GB210A.

- (2) It takes 180 seconds for the main unit to boot. Wait a while until the screen moves to the next one.

- (3) Press **NEXT** key. If you want to calibrate the oxygen sensor, press **O2 CAL** key. At this time, the blower will start and set the blower volume to 0.3 - 0.5m³/min. Also, open the left side door and set the flow meter for the oxygen sensor (smaller flow meter) to 0.5 - 0.8L/min. Calibration will finish automatically in 10 minutes.

The unit is normal if the oxygen concentration monitor in the operation panel of GAS410 indicates between 18% to 22% after calibration. (See page 40: Calibration in the atmosphere) If do not need to CAL, At first, do not press **O2 CAL**, press **NEXT** key.

The screen will automatically moves to the next one after calibration or press **NEXT** key.

※ Any key operation will be invalid until the timer counts becomes 0s. When connected to GAS410, the blower of ADL311S or GB210A will not be used. Use the volume of GAS410 for adjustment of air amount.

※ Use **HELP** key to move to the manual and language select screen, confirm the operation manual and you can select an OSD language (English, Japanese, Chinese).



- (4) Please set N₂ supply pressure as 0.1MPa, set appropriate control temp. of condenser, set **BLOWER** switch ON and air flow 0.3-0.5m³/min, meanwhile the refrigerator starts.

The refrigerator contains delay timing circuit. Because it will take 3mins to start after refrigerator stops, the refrigerator may not activate immediately if press **BLOWER** switch.

During operation, when the condenser temp. is lower than set temp., the refrigerator will stop to prevent solvent concretion or sublimation after liquefying when temp. is lower, which may cause pipe blocking. Please according to the characteristics of solvent, set an appropriate control temp. of condenser.

4. Operating procedures

Operating method

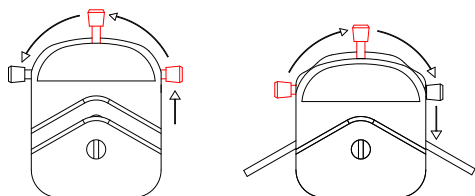
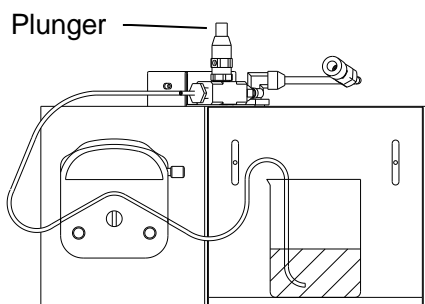
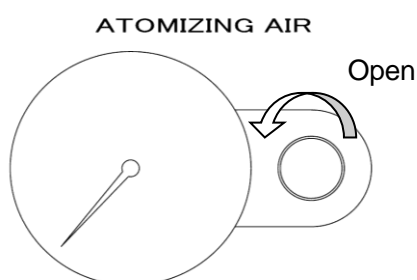
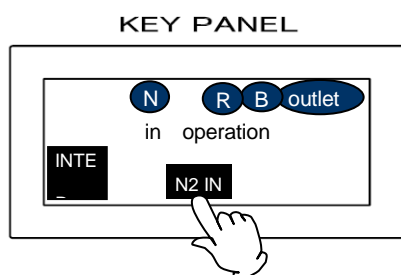

- (5) Turn the N2 IN switch ON. At the same time, open the left side door and set the flow meter for introducing N₂ (larger flow meter) to 40 - 50L/min.

When oxygen concentration drops to 8%, the compressor integrated in GAS410 will activate. At the same time, supply of N₂ gas from the pulse jet device is stopped, the solenoid valve for automatic control of N₂ gas is opened, and supply N₂ gas is started. Set spray pressure to 0.05-0.1MPa. **When oxygen concentration reaches 3.4%, introduction of N2 gas control solenoid valve close and the screen shifts to the next screen. And after oxygen concentration become over 3.6%,N2 gas control valve is open. Then supply N2 gas again. N2 gas concentration control by this solenoid valve(Open/Close)**

Set the liquid tube as shown in the left diagram. Push the pump rod CCW to open the pump head, put the liquid sending tube in it, and then push the rod CW to have the tube stuck. In terms of liquid specimen, set the solvent only.

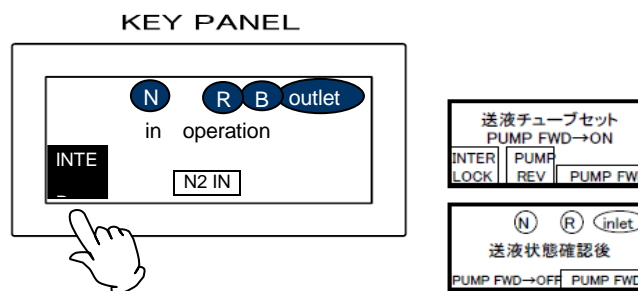

If you want to operate the liquid sending pump, push **INTER LOCK** → **PUMP FWD** (forward) or **PUMP REV**(reverse).

To finish operation of the pump, press **INTER LOCK** to return to the previous screen.

※ When specimen is not sprayed any more, it is suspected that the orifice of the spray nozzle is clogged, which can be cleared by pressing the plunger at the upper part of the nozzle (Refer to "Exploded view of the spray nozzle" in the instruction manual of ADL311S · GB210A). The needle pushes out the clog in the orifice.

4. Operating procedures

Operating method



KEY PANEL

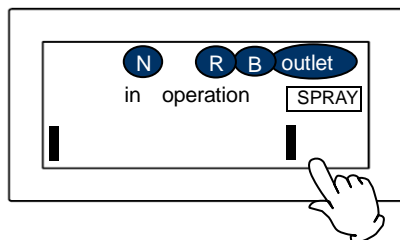

- (6) You select temperature control for inlet or outlet temperature using SWITCHING. When you want to control temperature by the outlet temperature, select inlet temperature at the start of operation switch to outlet temperature once the temperature has stabilized. When operation of N₂ IN has finished and the screen has changed, set a temperature on the inlet temperature controller and turn the heater ON.

* Setting ranges will differ among temperature controllers.
 Outlet temperature setting range: 0 to 60°C
 Inlet temperature setting range: 0 to 150°C

KEY PANEL

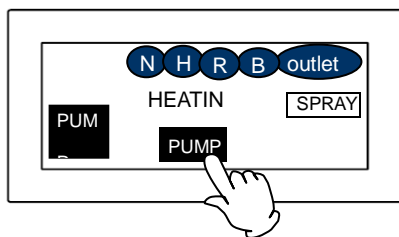

- (7) When the inlet and outlet temperatures have risen to or above the temperature you want and the cooling trap temperature has dropped is stable, set the spray pressure, turn the pump FWD switch ON, and send solvent liquid. Also, open the ball valve above the collecting flask to start recovering solvent.

KEY PANEL

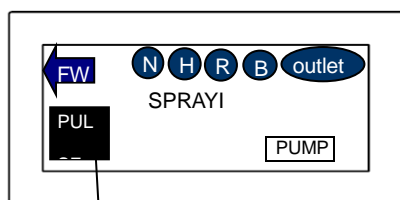

When the specimen accumulated on the nozzle tip while spraying it, you can clean it off using PULSE JET.

- (8) Readjust dry air amount, spray pressure, and liquid sending speed so that the inlet and the outlet temperature will be stable at the temperatures you want.

~Hint~

- Influences below are of specific settings on the outlet temperature when the inlet temperature is constant.
 - Sent specimen liquid amount
 - small : outlet temperature →high
 - Circulation air amount
 - large : outlet temperature →high
 - Specimen density (external factor)
 - high : outlet temperature →high
- Drops of sprayed liquid will become fine at a higher spray pressure.
- When specimen is switched from solvent liquid to the specimen actually used, the outlet temperature will be slightly higher because of non-evaporated component (solid component).

4. Operating procedures

Operating method

- (9) When the outlet temperature has become stable, change the solvent with the actual specimen. At this time the outlet temperature will change slightly and adjust liquid sending speed again when necessary.

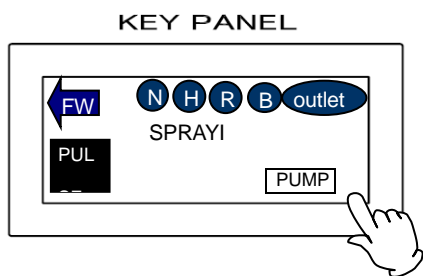

~Finishing process~

- (10) When specimen has been sent, change the specimen back to solvent and clean inside the nozzle. Clean inside the nozzle for about five minutes, turn the pump FWD switch OFF, and then choke the spray pressure to 0.

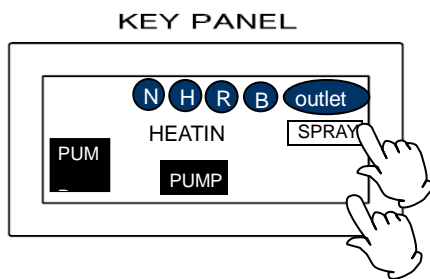

- (11) Turn the spray switch and the heater switch OFF.

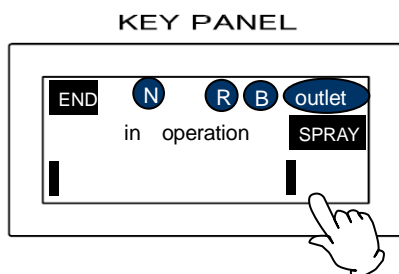

- (12) Some solvent will remain in the path for some time after spraying of solvent has finished. Continue operation for a while to completely recover solvent. When solvent contains water content, the cooling trap may be frosted and the amount of solvent recovered may decrease. If amount of solvent recovered in the collecting flask is too small, stop the freezer once with the DEFROST switch and allow frost on the cooling trap to melt. The freezer will automatically recover after five minutes.

When the inlet temperature drops to 60°C or below and the outlet temperature drops to 50°C or below, the END switch will appear at the upper left portion on the screen. When recovering of solvent has finished, press END switch to switch the screen.

Close the supply cock of N₂ gas.

4. Operating procedures

Operating method

KEY PANEL

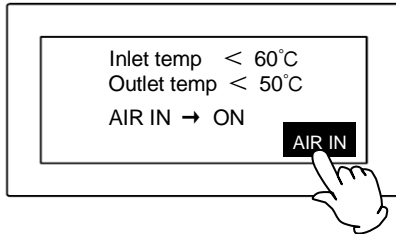

- (13) Return the oxygen concentration in the path to the atmospheric concentration with AIR IN switch.

KEY PANEL

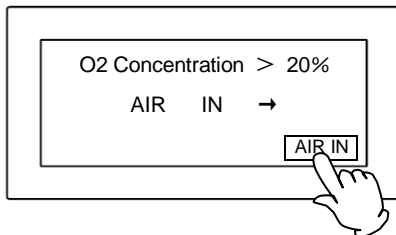

- (14) Turn AIR IN OFF when oxygen concentration has returned to around 18 - 22%.

ATOMIZING AIR

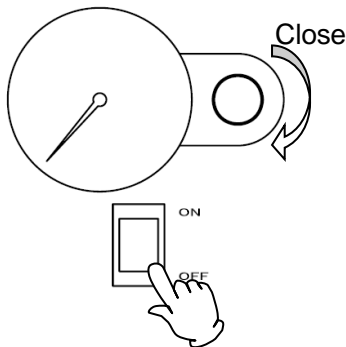

- (15) Choke the spray pressure to 0.

- (16) Turn the power switch of ADL311S or GB210A and GAS410 OFF.

KEY PANEL

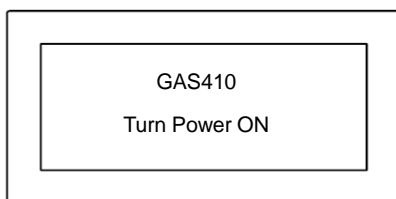

- (17) Remove the container holding band and take out the product collecting container. When taking out the container, take care the powder attached on the back side of the cyclone cover.

- (18) Hold the collecting flask by hand, remove the clamp and then remove the collecting flask and recover the solvent.

- (19) Wash the containers according to the maintenance method for ADL311S and GB210A.









4. Operating procedures

Operating method

KEY PANEL Description of indication lamps

You can confirm the operating statuses of switches one the KEY PANEL by checking whether a specific lamp is on or off.

Each lamp will be turned on at the upper right corner on the KEY PANEL.

	Lamp on: Indicates that the spray nozzle is attached. Lamp blink: Indicates that a spray nozzle is not attached.
	You can control temperature by setting a temperature on the outlet side temperature controller while the lamp is on.
	You can control temperature by setting a temperature on the inlet side temperature controller while the lamp is on.
	When the lamp is on, the blower is in operation.
	When the lamp is on, the heater is in operation.
	When the lamp is on, the liquid sending pump is operating in the normal direction.
	When the lamp is on, the liquid sending pump is operating in the reverse direction.
	When this lamp is on, it indicates that the freezer is operating. When this lamp is flashing, the freezer is in the standby mode due to the delay timer. The lamp shifts to lit status when the timer countdown finishes and the freezer is activated.

When you want to abort processing of the sample, or when the nozzle is clogged

Abort sending liquid following operations of the ending process (P19 (10) ~P20 (18)) when you want to abort processing of the sample or the nozzle is clogged.

And if you want to process another sample, recover contents in the product collecting container, clean it according to the maintenance method (P24." Cleaning After Using "), and then operate the unit using another sample.

4. Operating procedures

Related Figure between Blower and Temperature/Circulating Air Quantity (Reference)

The temperature around outlet is depended on the circulating air flow rate of the blower. Also, this temperature is depended on the clogging of the filter in the blower. Refer to the following table for each dial value of the blower and the display temperature around inlet/outlet as the guideline of the work.

Display temperature of outlet (°C)			
Setting temperature of inlet Blower dial value	50°C	100°C	150°C
0~4	44	73	97
4.5	44	75	98
5.5	45	76	100
7	45	76	101
8.5	46	78	102
10	47	79	103

The table below shows the relationship between dial values of the blower and average circulating air amount.

Use this table as a reference for work. When the filter is clogged, air amount for the specific dial setting may decrease. Clean the filter according to the maintenance method when the reading on the filter differential pressure meter has become about twice of the ordinary value.

Blower dial value	Average flow rate of circulating air (m ³ /min)
0	0.13
1	0.17
2	0.21
3	0.24
4	0.27
5	0.31
6	0.35
7	0.39
8	0.43
9	0.47
10	0.51
MAX	0.65

5. Handling Precautions

Warning

1. Substances that cannot be used

-  Such substances may cause an explosion or a fire. Whether a solvent may be used or not shall be judged according to "About specified organic solvents" in section 5. Handling precautions.

Always monitor the oxygen concentration during operation to assure safety.

See "13. List of Dangerous Substances" on P.47.

2. If a problem occurs

-  If smoke or strange odor should come out of this unit for some reason, turn off the power key right away, and then turn off the circuit breaker and the main power. Immediately contact a service technician for inspection. If this procedure is not followed, fire or electrical shock may result. Never perform repair work yourself, since it is dangerous and not recommended.

Caution

1 Do not put anything on this unit.

-  Do not put anything on this unit. It will cause injury if fall.

2. During a thunder storm

-  During a thunderstorm, turn off the power key immediately, then turn off the circuit breaker and the main power. If this procedure is not followed, fire or electrical shock may be caused.

3. After installing

-  It may cause injure to a person if this unit falls down or moves by the earthquake and the impact, etc.. To prevent, take measures that the unit cannot fall down.

5. Handling precautions

About applicable organic solvents

This unit has been designed to use isopropyl alcohol and ethanol. Note that the following restrictions shall apply when other organic solvents are used.

(1) Restrictions because of explosion limit oxygen concentration

When N₂ gas, organic solvents, and air (oxygen) are mixed, explosion will occur when the oxygen concentration is over the oxygen concentration limit and if there is an ignition source. This means that it is desirable the oxygen concentration limit of a solvent is as high as possible.

The oxygen concentration limit for this unit is 9%. Do not use any organic solvent whose oxygen concentration limit is below 9%. (See "Oxygen concentration limit table" on P.25. Also, calculate limits for organic solvents not shown in the table using the "calculation method of concentration limits".

(2) Restrictions because of the boiling point

Although the unit recovers solvent by cooling it in the condenser (cooling trap), the outlet temperature of the condenser (TRAP TEMP MONITOR) may become considerably high depending on the outlet temperature, amount of liquid that is sent, environmental temperature, or duration of sending liquid.

{ Example }

Environmental temperature: 35°C Amount of liquid to send: 2000mL/H (ethanol)

Air amount: 0.5m³/min Liquid sending time: 30 min

Outlet temperature: 100°C Condenser outlet temperature: 37°C

Thus a solvent with a lower boiling point may not be condensed efficiently. (See "Table of oxygen concentration limit" on P.25.) In fact, you do not need to set inlet and outlet temperature higher when you use a solvent with a low boiling point. For example, you can operate the unit with lower condenser outlet temperature by reducing the air amount and amount of liquid to send for solvents with a low boiling point such as methylene chloride.

{ Example }

Environmental temperature: 25°C Amount of liquid to send: 1170mL/H (methylene chloride)

Air amount: 0.45m³/min Liquid sending time: 20 min

Outlet temperature: 38°C Condenser outlet temperature: 14°C

(3) Restrictions because of boiling points

When the solvent contains an organic solvent with a high melting point or water, too low trap temperature might cause it condensate in the condenser. In such a case, raise the trap temperature by increasing air amount, increasing the inlet temperature, or increasing the amount of liquid to send, or stop the freezer once with DEFROST switch and allow condensed solvent or water to solve. (When the trap temperature is lower than the melting point before sending solvent, watch the trap temperature a while because that temperature will rise once sending of solvent is started.)

When you use a water soluble solvent, try to disconnect this unit and operate with ADL311S or GB210A only.

(4) Restrictions because of corrosion resistance

This unit has been designed to use isopropyl alcohol and ethanol. When other solvents are used, care must be taken because service lives will differ from part to part. See the table of corrosion resistance on P.26 and the piping system drawing that shows parts made of materials other than stainless steel or glass on P.27. In terms of this unit, components other than the liquid sending tube are exposed to thin solvent steam only and will not immediately corrode even if they are exposed to chemicals marked with Δ or \times in the corrosion resistance table, if any abnormalities such as abnormal increase speed of oxygen concentration or a gas leakage in the pipe path, replace defective parts immediately because service life of some parts may be shortened due to solvents other than ethanol and isopropyl alcohol.

5. Handling precautions

About applicable organic solvents

Chemicals that each type of liquid sending tubes are as follows.

Silicone tube: ethanol, isopropyl alcohol, methanol, acetone, acetic ether

Viton tube: xylene, toluene, benzene, hexane, chloroform, methylene chloride

[Oxygen concentration limit table]

Organic solvent	Boiling point [°C]	Melting point [°C]	Oxygen concentration limit [%]
Xylene	(o) 144 (m) 139.3 (p) 138.5	(o) -25 (m) -47.4 (p) 13.2	(o) 10.5 (m) 11.5 (p) 11.5
Isopropyl alcohol	82.3	-88	9.0
Benzene	80.1	5.5	10.5
Ethanol	78.4	-114.3	9.9
Acetic ether	77.1	-83.6	10.0
Hexane	67.7	-95.3	11.4
Methanol	64.6	-97.4	9.7
Chloroform	61.2	-63.5	Non-combustible
Acetone	56.2	-94.6	10.4
Methylene chloride	40	-97.7	23.9

[How to calculate an oxygen concentration limit]

Molecular formula of flammable gases: $C_a H_b O_c N_d S_e F_f$ (F means halogen) d is not used.

$$v = \frac{100}{1 + 4.773 \left[a + e + \frac{b-2c-f}{4} \right]}$$

Oxygen concentration limit

$$= [100 - \{L + (1 - L/v) \times 100\}] \times 0.209 \quad [\%]$$

Example: Toluene

According to the molecular formula $C_6H_5CH_3$, $a=7$, $b=8$, $c=e=f=0$

Lower explosion limit $L=1.2$

$$v = \frac{100}{1 + 4.773 \left[7 + 0 + \frac{8-0-0}{4} \right]} = 2.27$$

Oxygen concentration limit

$$= [100 - \{1.2 + (1 - 1.2/2.27) \times 100\}] \times 0.209$$

$$= 10.7\%$$

5. Handling precautions

Corrosion resistance table

○: Usable △: Avoid using preferably x: Unusable for use

Material	Silicone rubber	Viton (FPM)	Chloroprene rubber (CR)	Nitrile rubber (NBR)	Steel acrylic phthalic acid resin paint	POM	Phenol	Polypropylene (PP)	Vinyl chloride (hard)	Polyacetal (PA)
Applicable parts	Glass connecting packing Liquid sending tube Diaphragm cap for the differential pressure meter Bond to glass	O-ring Solenoid valve seal Liquid sending hoses Packing for installing the oxygen concentration measurement sensor	Filter bottom packing Oxygen concentration meter (pump valve, diaphragm)	Nozzle packing Blower oil seal Pressure meter packing Needle valve packing	Blower air contact part	Needle valve BOX for installing the oxygen concentration measuring sensor	Bonding of aluminum honeycomb Hoses	Compressor cover		Tube coupler
Xylene	x	○	x	△~x	△	○	○	△	x	○
Toluene	x	○	x	△~x	△	○	○	△	x	○
Isopropyl alcohol	○	○	○	○	○	△	○	○	○	○
Benzene	△	○	x	x	△	△	○	△	x	○
Ethanol	○	○	○	○	○	○	○	○	○	○
Acetic ether	△	○	△	△~x	△	○	○	△	x	⊗
Hexane	x	○	○	○	△	○	○	△	○	⊗
Methanol	○	x	○	○	○	△	△	○	○	△
Chloroform	x	○	x	x	△	x	○	x	x	x
Acetone	○~△	x	○~△	△~x	△	△	○	△	x	○~△
Methylene chloride	x	○	x	x	△	x	○	△	x	x
Ethylene chloride	○~△	○	x	x	△	x	⊗	○	x	x

5. Handling precautions

List of materials

No.	Part name	Material	No.	Part name	Material
①	Capacitor	SUS304	A	O-ring	Viton Adhesive: Silicone
②	Sensor	Stainless steel			
③	Ball valve	Stainless steel			
④	Clamp	Polyacetal	※ All O-rings are made of Viton.		
⑤	Collecting flask	Glass	B	Packing	Silicone
⑥	Filter element	Filtering material : Glass wool Adhesion: Epoxy Packing: chloroprene	C	Hose	Teflon
⑦	Filter case	SUS304 Packing: silicone	D	Spray nozzle	Seal: Haika (NBR) Teflon
⑧	Differential pressure meter	ABS resin Diaphragm: Silicone Connecting hose: Viton	E	Tube	Teflon
⑨	Flow meter (for introducing N ₂)	Air contact assembly: Viton, Teflon Connecting hose : Teflon	F	Aluminum honeycomb	Adhesive: phenol
⑩	Compressor	Cover case: PP Connecting hose : Teflon	G	Cap	Silicone
⑪	Solenoid valve (for N ₂ control)	Seal assembly: Teflon	H	Pressure meter	
⑫	Flow meter (for measuring O ₂ concentration)	Air contact assembly: Viton, Teflon Connecting hose: Viton	I	Needle valve	Seal assembly: Teflon Viton
⑬	Filter	Connecting hose: Viton	J	3-way valve (for switching connection of GAS410)	Seal assembly: Teflon
⑭	Pump	Valve: Chloroprene Connecting hose: Viton	K	Solenoid valve (for pulse jet)	Seal assembly: Teflon
⑮	O ₂ sensor	Case: Polyacetal Packing: Viton Connecting hose: Viton	L	Packing	Silicone
⑯	Solenoid valve (for exhaust)	Seal assembly: Teflon Connecting hose : Teflon			
⑰	Blower	Oil seal: NBR Air contact assembly: Steel acrylic phthalic acid resin paint			
⑱	Solenoid valve (for introducing N ₂)	Seal assembly: Fluoro-rubber			
⑲	Solenoid valve (for suction)	Seal assembly: Fluoro rubber			

5. Handling Precautions

Precautions during operation

- (1) Be sure to connect the earth wire when connecting power supply.
- (2) Securely connect with ADL311S or GB210A.
- (3) Using the blower at a low air amount may cause a malfunction. Set it at least 0.2m³/min or more.
- (4) Flow meter for the oxygen sensor (small) and a flow meter for introducing N₂ (large) are located inside the left side door. Adjust the flow meter for the oxygen sensor to 0.2L/min at **AIR IN** during preparations and adjust the flow meter for introducing N₂ to 35~40L/min when performing **N₂ IN**.
- (5) When this unit is connected to ADL311S or GB210A, the blower of ADL311S or GB210A cannot be used. Use the dial of GAS410 for setting an air amount.
- (6) Make sure that the glass chamber is fixed at the specified position without any play. Check the connecting assembly when oxygen concentration will not decrease properly or its increase speed has risen.
When a defect at a connection of pipes or at a packing is suspected, repair or replace the relevant part.
- (7) Do not heat up the temperature around outlet over 100 Celsius degree, for the material of the suction/exhaust hose, material of the filter, and performance of the blower may be deteriorated..
- (8) Check the glass chambers are fixed to the specified position with no gap, and then turn on the switches of blower and heater.
- (9) The unit is not explosion proof. You cannot use this unit in an atmosphere where a flammable gas exists or at a place where a flammable gas may be produced.
- (10) If the leakage is existed between container for product and bracket at lower of the cyclone, the dried powder may be stocked onto the lower of the cyclone without falling into the container for product. Therefore, pay special attention to the unit with the container for product be mounted.
- (11) When the heater is ON, do not expose the cap and bayonet of the spray nozzle to the non-guard status, and do supply the air to the heater part for at least 0.1 to 0.2m³/min.
- (12) If the sample is not fed from the feeding pump, the following causes may be considered; the sample tube is crushed at the roller of the pump, the inner wall of the tube is adhered tightly without restoration, or the inner of the nozzle is blocked. Remove the cause, and reset to the normal status.
- (13) Do not perform unattended operation during activating the unit. Since the unit is in idling status and the nozzle is blocked of after the operation using sample, the temperature around outlet is increased and the remaining sample is flown from the sample tube disconnected from the unit, and these failures may cause the indeterminism accident.
- (14) There are to types of specimen tubes, those made of silicone and those made of Viton. Take care they might be corroded, swell and break with some solvents during operation.
- (15) When the high temperature is set to the temperature around inlet for the operation, supplying too excessive airflow of the blower to the unit may not reach the temperature to the setting one caused by not keeping balance with the heater capacity. To resolve this error, turn down the airflow of the blower, increase the setting temperature, and operate this unit. To avoid a malfunction of the blower, set the air amount below the red zone on the dial scale. When you operate the unit at a higher set temperature, the setting and the actual inlet temperature will not match.
The heater will stop automatically when the inlet temperature exceeds 230°C, or when the outlet temperature exceeds 110°C.

5. Handling Precaution

Caution during operation

- (16) If this unit is not operated, turn "OFF" the earth leakage breaker on the back of the unit.
- (17) The cyclone may charge easily with static electricity depending on the specific specimen used, or operating environment or conditions. Implement countermeasures against static electricity such as attaching included earth clips at three positions on the clamp at the connection of the cyclone or attaching an antistatic brush to the body of the cyclone.
- (18) Depending on the sample to be processed, the static electricity may be occurred at cyclone. Therefore, remove the static electricity with the appropriate method. It is efficient that the wire is wounded to the glass portion for grounding, but it is more convenient to use the static electricity remover by setting against the cyclone vertically.

6. Maintenance Method

Daily Inspection and Maintenance

Warning

- Disconnect the power cable from the power source when doing an inspection or maintenance unless needed.
- Perform the daily inspection and maintenance after returning the temperature of this unit to the normal one.
- Do not disassemble this unit.

Caution

- Use a well-drained soft cloth to wipe dirt on this unit. Do not use benzene, thinner or cleanser for wiping. Do not scrub this unit. Deformation, deterioration or color change may result in.



Monthly maintenance

- Check the earth leakage breaker function.
 - Connect the power cord.
 - Turn the breaker on.
 - Push the red test switch by a ballpoint pen etc. If there is no problem, the earth leakage breaker will be turned off.

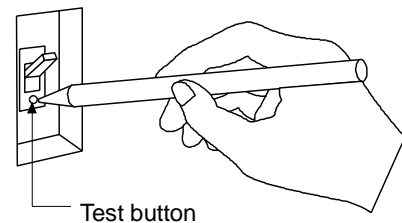

6. Maintenance Method

Daily Inspection and Maintenance

 **Caution**

Filter cleaning

- Filter element

The clogging standard of filter mesh is that the indication on the filter differential pressure gauge is about twice of ordinary indication.

When the filter is clogged, open the left side door of the unit, open the filter case cover, tear off the filter seal sticker, and then loosen and remove the butterfly nut that fix the filter. When assembling, please paste the accessorial filter seal sticker in the last step, after pasting, the concave of filter will be completely hidden.

To remove clogging of filter mesh, beat lightly to remove dusts off. (The filter cannot be washed by water.) Replace with a new one if clogging occurs too often after cleaning.

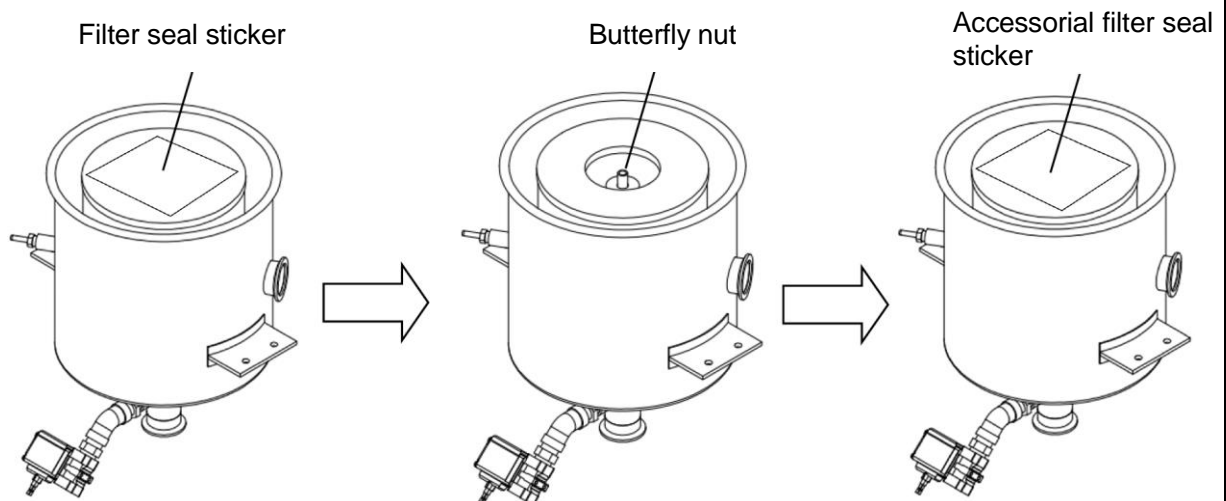

- Filter case

Remove the filter element and remove dusts attached inside the filter case or on the bottom by suctioning with an electric cleaner or by wiping out with a cloth. During this work, take care so that dusts will not fall on the pipe port on the bottom.

- Freezer filter

There is a filter for the freezer capacitor at the lower right position of the front of the unit. The filter cover is held with magnets. Lightly pull it toward you by hand to remove it and then clean the filter. To clean, gently wash it with water or remove dusts using a cleaner. When capacitor fins at the deep back of the filter are clogged with dusts, remove them with a cleaner.

- For the oxygen filter sensor

Open the door at the left side of the unit and remove the filter fixed to the front pole.

You can remove the filter holding screws by hand. (See P.9 of the operation manual.)

Rough replacement interval of the filter shall be about six months.

6. Maintenance procedures

Daily inspection / care

Gas selector switch

GAS410 the maximum pressure within the compressor output is 0.1Mpa, if you need to use higher pressure, please use the external N2 bomb gas.

1. Gas selector switch, select "Internal compressor".
2. Gas selector valve 90 degrees clock wise, make sure the direction of the arrow above the valve handle. (Use N2 bomb pressure for Nozzle spray).

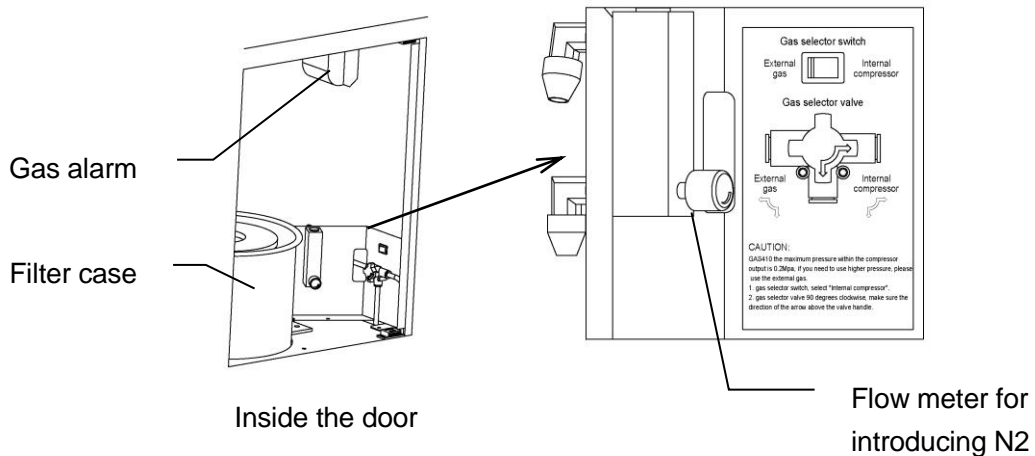

Supply oil to the blower

Exchange lubrication oil after 500 hours of operation (about 20 days) of initial operation after installation and each of about 2000 hours of operation (about three months) thereafter.

- ① Remove the blind plates on the right side plate and at the lower right of the rear side.
- ② Stop the blower, remove the oil drain plug, and allow all old oil to discharge.
- ③ Replace the plug, and fill new lubrication oil to the line of the oil gauge taking care dusts will not enter at the upper oil filler port. (Approx.0.3L)

Lubrication oil brands

Appropriate oil is additional turbine oil No.3 (#180) of JIS K2213 or equivalent. Typical brands are as follows.

	Mobil	Esso	Idemitsu	Mitsubishi	Nisseki	Showa Shell	Kyoseki	Cosmo
No. 3	DTE oil heavy medium	Teresso 68	Daphne turbine oil 68	Diamond turbine oil 68	FBK turbine 68	Turbo oil T68 J-H oil68	Kyoseki RIX turbine 68	Cosmo turbine super 68

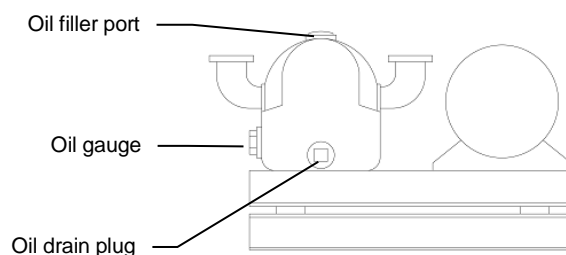

7. Long storage and disposal

When not using this unit for long term / When disposing



Caution

When not using this unit for long term...

- Turn off the earth leakage breaker and original power source for safe without fail. Also, store the glass unit after removing it from the main unit. When the glass unit is contacted to the external, it may cause the breakage.



Warning

When disposing...

- Keep out of reach of children.
- Remove the power cord.

Matters to consider when disposing of the unit

Environmental protection should be considered

- We request you to disassemble this unit as possible and recycle the reusable parts considering to the environmental protection. The feature components of this unit and materials used are listed below.

Component Name	Material
Parts of Main Unit	
Casing	Bonderizing steel plate baked with melamine resin coating, Stainless steel
Insulating material	Ceramic Felton
Capacitor (cooling trap) Filter case Pipes, couplers	Stainless steel
Production plates	Polyethylene (PET) resin film
Tube	Silicon rubber, Teflon, Viton
Electrical Parts	
Freezer	Stainless steel, iron, copper, aluminum, etc.
Compressor	Iron, PP, etc.
Circuit boards	Composites with board, condenser, resister and transformer
Power cord & wiring materials and others	Synthetic rubber, resins
Sensor	Stainless steel and others

8. When a trouble occurs

Safety unit and error indications

The table shows possible causes of activation of the safety unit and solutions.

[Error indication]

When an abnormality occurs to the inlet temperature controller or the outlet temperature controller, the touch panel at the operation panel displays the error screen. When an abnormality occurred, confirm description of the error and implement appropriate solutions.

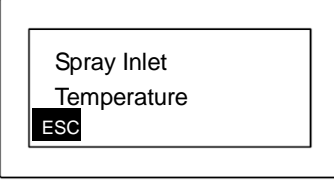
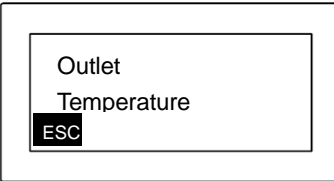
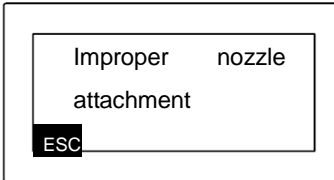
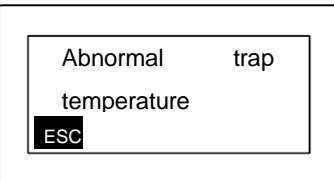
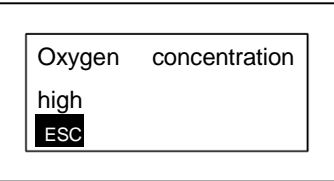
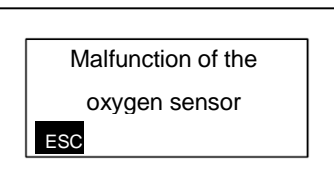
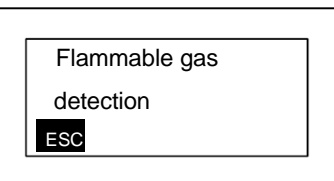
Display	Possible causes	Solutions
	<ol style="list-style-type: none"> ① Disconnection of the thermocouple sensor ② When the displayed inlet temperature is at 230°C or over ③ Malfunction of the blower 	<ol style="list-style-type: none"> ① Replacement of the thermocouple sensor ② Lower the set temperature or adjust air amount.
	<ol style="list-style-type: none"> ① Disconnection of the thermocouple sensor ② When the displayed outlet temperature is at 110°C or over ③ Malfunction of the blower or inverter 	<ol style="list-style-type: none"> ③ Replacement of the part
	<ol style="list-style-type: none"> ① The nozzle detached while spray was in operation. ② Disconnection of the limit switch for detecting a spray nozzle 	<ol style="list-style-type: none"> ① Install a spray nozzle. ② Replace
	<ol style="list-style-type: none"> ① When the measured cooling trap temperature becomes 40 °C or more. ② Imperfect connection or disconnection of the temperature sensor. ③ Malfunction of the display monitor (temperature controller) ④ Malfunction of the freezer or the inverter 	<ol style="list-style-type: none"> ① Possible causes include clogging of the freezer filter, high room temperature, or large circulating air amount. Implement solutions appropriate for the symptom. ② Repair or replace ③ Replace ④ Replace
	<ol style="list-style-type: none"> ① While oxygen concentration in the pipe path becomes 5% or more during heating. ② Imperfect connection or disconnection of the oxygen sensor ③ Malfunction of the oxygen sensor substrate 	<ol style="list-style-type: none"> ① Isolate the cause of the leak and repair or replace the defective part. ② Repair or replace ③ Replace
	<ol style="list-style-type: none"> ① Imperfect connection or disconnection of the oxygen sensor ② Malfunction of the oxygen sensor substrate 	<ol style="list-style-type: none"> ① Repair or replace ② Replace
	<ol style="list-style-type: none"> ① When leak of a flammable gas is detected in the piping path in the unit. 	<ol style="list-style-type: none"> ① Assure sufficient ventilation around the unit, inspect for the cause of the leak, and repair or replace the defective part.

8. When a trouble occurs

Safety unit and error indications

Display	Possible causes	Solutions
<div style="border: 1px solid black; padding: 10px; width: fit-content;"> <p style="text-align: center;">Blower Overheat</p> <div style="border: 1px solid black; padding: 2px; display: inline-block; background-color: black; color: white; font-weight: bold;">ESC</div> </div>	<ul style="list-style-type: none"> ① Supply voltage too high or too low ② Motor mechanical failure ③ Ambient temperature is too high or ventilation holes are blocked. ④ Blower Inverter Fault 	<ul style="list-style-type: none"> ① Check the power supply voltage ② Repair or replace ③ Lower ambient temperature or cleaning the plug to ensure a well-ventilated ④ Repair or replace
<div style="border: 1px solid black; padding: 10px; width: fit-content;"> <p style="text-align: center;">Refrigerator Overheat</p> <div style="border: 1px solid black; padding: 2px; display: inline-block; background-color: black; color: white; font-weight: bold;">ESC</div> </div>	<ul style="list-style-type: none"> ① Supply voltage too high or too low ② Motor mechanical failure ③ Ambient temperature is too high or ventilation holes are blocked. ④ Refrigerator Inverter Fault 	<ul style="list-style-type: none"> ① Check the power supply voltage ② Repair or replace ③ Lower ambient temperature or cleaning the plug to ensure a well-ventilated ④ Repair or replace

8. When a trouble occurs

Confirmation and language select for the manual

You can select English or Chinese with the language select function for the manual.

[Confirmation and language select for the manual] Pressing ESC key will return to the standby screen.

Select Language [ENGLISH] [日本語] [中文] ▲	言語切換 [ENGLISH] [日本語] [中文] ▲	選擇語言 [ENGLISH] [日本語] [中文] ▲
This Machine Used For Organic Solvent ESC [MANUAL] [LANGUAGE]	本装置は 有機溶剤対応です ESC [MANUAL] [LANGUAGE]	此裝置 適用於有機溶劑 ESC [MANUAL] [LANGUAGE]
*O2 CAL→Start *Flow Rate: 0.5L/min *Autostop In 10min ESC [BACK] [NEXT]	◇[O2 CAL]開始 ◇流量設定:0.5L/min ◇10分後自動停止 ESC [BACK] [NEXT]	◇[O2 CAL]開始 ◇流量設定:0.5L/min ◇10分後自動停止 ESC [BACK] [NEXT]
*BLOWER→Start *Set Air Flow Volume ESC [BACK] [NEXT]	◇[BLOWER] ON ◇風量を設定する ESC [BACK] [NEXT]	◇[BLOWER] ON ◇風量設定 ESC [BACK] [NEXT]
*N2 IN→Start *Pressure: 0.1MPa *Flow Rate: 30L/min ESC [BACK] [NEXT]	◇[N2 IN]供給開始 ◇設定圧力:0.1MPa ◇設定流量:30L/min ESC [BACK] [NEXT]	◇[N2 IN]供給開始 ◇設定圧力:0.1MPa ◇設定流量:30L/min ESC [BACK] [NEXT]
*INTER LOCK→OFF *Set Tube & Solvent *INTER LOCK→ON ESC [BACK] [NEXT]	◇[INTER LOCK] OFF ◇送液チューブ・溶媒セット ◇[INTER LOCK] ON ESC [BACK] [NEXT]	◇[INTER LOCK] OFF ◇送液管・溶媒設置 ◇[INTER LOCK] ON ESC [BACK] [NEXT]
*When O2<5% Set Spray Pressure *N2<3.4% Autostop N2 ESC [BACK] [NEXT]	◇酸素濃度5%以下で スプレー圧力を設定 ◇3.4%以下でN2停止 ESC [BACK] [NEXT]	◇O2濃度降到5%以下 設定噴霧圧力 ◇3.4%以下N2自動停止 ESC [BACK] [NEXT]
*INLET→Select *Set Inlet Temp *HEATER→ON ESC [BACK] [NEXT]	◇[INLET]選択 ◇[INLET]温度設定 ◇[HEATER] ON ESC [BACK] [NEXT]	◇選択[INLET] ◇設定[INLET]温度 ◇[HEATER] ON ESC [BACK] [NEXT]
*Wait Inlet Temp Stabilized *Outlet Changeable ESC [BACK] [NEXT]	◇温度の安定を待つ [INLET]温度安定後 ◇[OUTLET]切替可 ESC [BACK] [NEXT]	◇等待温度安定 入口温度安定後 ◇可切换到出口控制 ESC [BACK] [NEXT]



*PUMP FWD→ON Adjust Solution Rate *Fine Adjust In Test ESC [BACK] [NEXT]	◇[PUMP FWD] ON 送液速度調整 ◇テスト運転で微調整 ESC [BACK] [NEXT]	◇[PUMP FWD] ON 調整送液速度 ◇試運行時再細調 ESC [BACK] [NEXT]
*After adjustment Set Sample Start Spray ESC [BACK] [NEXT]	◇微調整終了後 溶媒から試料へ切替へ スプレー開始 ESC [BACK] [NEXT]	◇細調之後 把溶媒換成試料溶液 噴霧開始 ESC [BACK] [NEXT]
*After Spray Sample Set Solvent Set Temp Down ESC [BACK] [NEXT]	◇試料噴霧終了後 試料から溶媒へ切替へ 設定温度を下げる ESC [BACK] [NEXT]	◇試料噴霧完之後 把溶媒換成溶媒 降低設定温度 ESC [BACK] [NEXT]
*Spray 5min Stop solution Pump, Heater and Spray ESC [BACK] [NEXT]	◇5分噴霧後 送液ポンプ・ヒータ スプレーを停止 ESC [BACK] [NEXT]	◇5分噴霧後 [PUMP FWD][SPRAY] [HEATER] OFF ESC [BACK] [NEXT]
After Solvent Collec- tion, AIR IN→ON, Stop N2 Supply ESC [BACK] [NEXT]	◇溶媒回収終了後 [AIR IN]で大気開放し 窒素供給停止 ESC [BACK] [NEXT]	◇溶媒回収完 [AIR IN]大気開放 停止供給N2 ESC [BACK] [NEXT]
*When O2> 20% AIR IN→OFF Cycle End ESC [BACK] [NEXT]	◇酸素濃度20%以上 [AIR IN]→OFFで 運転終了します ESC [BACK] [NEXT]	◇酸素濃度20%以上 [AIR IN]→OFF 装置運行停止 ESC [BACK] [NEXT]
*Inlet Temp < 60°C *Outlet Temp < 50°C *Blower Autostop ESC [BACK] [NEXT]	◇入口温度60°C以下 ◇出口温度50°C以下 ◇BLOWERが自動停止 ESC [BACK] [NEXT]	◇入口温度60°C以下 ◇出口温度50°C以下 ◇BLOWER自動停止 ESC [BACK] [NEXT]
*Power OFF *Take Out Powder And Solvent ESC [BACK] [NEXT]	◇電源スイッチをOFF ◇粉体・溶媒を回収 ESC [BACK] [NEXT]	◇[POWER] OFF ◇取出粉体及溶媒 ESC [BACK] [NEXT]
Do Maintenance According To Manual ESC [BACK] [NEXT]	取扱説明書に従い 定期点検及び 清掃を行って下さい ESC [BACK] [NEXT]	請按照使用說明書 進行定期檢查 並清掃機器 ESC [BACK] [NEXT]
Sol Speed ↑ OutTemp ↓ Air Vol ↑ OutTemp ↑ Spl Cone ↑ OutTemp ↑ ESC [BACK] [NEXT]	送液速度 ↑ 出口温度 ↓ 風量 ↑ 出口温度 ↑ 試料濃度 ↑ 出口温度 ↑ ESC [BACK] [NEXT]	送液速度 ↑ 出口温度 ↓ 風量 ↑ 出口温度 ↑ 試料濃度 ↑ 出口温度 ↑ ESC [BACK] [NEXT]

8. When a trouble occurs

Confirmation and language select for the manual

You can select English or Chinese with the language select function for error display and comments./.

*Language selection for error display

Spray Nozzle Not Mounted [ESC]	ノズル装着異常 [ESC]	噴霧器頭安裝警報 [ESC]
Spray Inlet Temperature Overheat [ESC]	入口温度異常 [ESC]	入口温度警報 [ESC]
Outlet Temperature Overheat [ESC]	出口温度異常 [ESC]	出口温度警報 [ESC]
Flammable Gas Detection [ESC]	ガス漏れ異常 [ESC]	可燃気体警報 [ESC]
Trap Temperature Overheat [ESC]	トラップ温度異常 [ESC]	回収温度警報 [ESC]
Oxygen Concentration Too High [ESC]	酸素濃度異常 [ESC]	O2濃度警報 [ESC]
Oxygen Sensor Error [ESC]	酸素センサ異常 [ESC]	O2伝感器警報 [ESC]
Blower Overheat [ESC]	ブロワー異常 [ESC]	鼓風機過熱警報 [ESC]
Refrigerator Overheat [ESC]	冷凍機異常 [ESC]	冷凍機過熱警報 [ESC]

* Language selection for comments

GAS410 TURN POWER ON	GAS410 電源を入れて下さい	GAS410 打開電源開關
SPRAY DRYER For Organic Solvent StartTime	スプレードライヤ 有機溶剤対応 起動時間	噴霧乾燥器 有機溶剤対応 起動時間
「O2 CAL」→ ON O2 Sensor CAL Starts CAL Time	「O2 CAL」→ ON 酸素センサ校正開始 校正時間	「O2 CAL」→ ON O2伝感器校正開始 校正時間
After O2 CAL Blower ON Start Operation	酸素センサ校正後 BLOWER ON 運転開始	O2伝感器校正後 BLOWER ON 運行開始
Set Solution Tube PUMP FWD→ON INTER LOCK PUMP REV PUMP FWD	送液チューブセット PUMP FWD→ON INTER LOCK PUMP REV PUMP FWD	安裝輸液管 PUMP FWD→ON INTER LOCK PUMP REV PUMP FWD
(N) (R) Inlet Check Solution Flow PUMP FWD→OFF PUMP FWD	(N) (R) Inlet 送液状態確認後 PUMP FWD→OFF PUMP FWD	(N) (R) Inlet 輸液状況確認後 PUMP FWD→OFF PUMP FWD
Inlet Temp < 60°C Outlet Temp < 50°C AIR IN→ON AIR IN	入口温度60°C以下 出口温度50°C以下 AIR IN→ON AIR IN	入口温度60°C以下 出口温度50°C以下 AIR IN→ON AIR IN
O2 Concentration Over 20% AIR IN→OFF AIR IN	酸素濃度20%以上 AIR IN→OFF AIR IN	O2濃度20%以上 AIR IN→OFF AIR IN

8. In the Event of Failure...

Trouble Shooting

Symptoms	Possible causes	Countermeasures
The POWER does not turn ON.	<ul style="list-style-type: none"> ● ELB is turned OFF ● Malfunction of the power supply ● The wire ire short-circuited. ● Malfunction of power switch 	<ul style="list-style-type: none"> ● Turn the ELB ON ● Check the power supply circuit ● Replace the cord ● Replace the power switch
The touch panel operation screen will not change even when the unit is connected to GAS410.	<ul style="list-style-type: none"> ● Imperfect connection of the connecting cable ● Connecting cable is defective 	<ul style="list-style-type: none"> ● Connect correctly as per the operation manual ● Replace the cable
Blower does not activate.	<ul style="list-style-type: none"> ● Incorrect connecting of the connector of blower ● Lubricating oil level is low ● Breaking of blower input cord ● Blower switch failure ● Blower or inverter failure ● Blower circuit failure and wiring failure 	<ul style="list-style-type: none"> ● Connect correctly. ● Exchange oil periodically ● Replace the card. ● Replace the touch panel, sequencer or thermo regulator. ● Replace the blower or inverter ● Maintain or replace the part
The freezer does not operate.	<ul style="list-style-type: none"> ● The delay timer is in operation ● Disconnection of the heater ● Touch panel or sequencer is defective ● Freezer circuit and wiring are defective 	<ul style="list-style-type: none"> ● Wait for five minutes and check whether the freezer operates or not ● Replace the heater ● Replace the touch panel or the sequencer ● Repair the defective points or replace the temperature controller
Spray pressure will not increase.	<ul style="list-style-type: none"> ● Dial is set at 0 ● Touch panel or sequencer is defective ● Imperfect connection of the tube ● Compressor is defective ● Defective solenoid valve ● Compressor circuit or wiring is defective 	<ul style="list-style-type: none"> ● Adjust the dial ● Replace the touch panel or the sequencer ● Repair or replace the defective points ● Replace ● Replace ● Repair the defective point
The value of oxygen concentration monitor cannot go beyond 18%	<ul style="list-style-type: none"> ● High altitude, low oxygen content ● Flowmeter of oxygen sensor is blocked ● Pump failure ● Filter degraded or blocking ● Oxygen sensor failure ● Oxygen sensor board failure 	<ul style="list-style-type: none"> ● Use it at proper altitude or use default oxygen concentration ● Replace the flowmeter ● Replace ● Replace the filter ● Replace ● Replace
Oxygen concentration will not decrease.	<ul style="list-style-type: none"> ● N2 supply source is defective ● Flow meter for introducing N2 is clogged ● Imperfect connection of the tube ● Defective solenoid valve ● Touch panel or sequencer is defective 	<ul style="list-style-type: none"> ● Take care so that oxygen concentration will not decrease ● Replace the flow meter ● Repair or replace the defective points ● Replace the solenoid valve ● Replace the touch panel or the sequencer

8. In the Event of Failure...

Trouble Shooting

Problem	Possible Cause	Solution
Indication on the oxygen concentration display monitor does not change.	<ul style="list-style-type: none"> ● Flow meter for the oxygen sensor is clogged ● Pump is defective ● Filter for the oxygen sensor is deteriorated or clogged ● Defect of the oxygen sensor ● Oxygen sensor substrate is defective 	<ul style="list-style-type: none"> ● Replace the flow meter ● Replace ● Replace the filter ● Replace ● Replace
The value of oxygen concentration monitor cannot recover beyond 18% after operation	<ul style="list-style-type: none"> ● Influenced by active carbon filter, the internal air oxygen concentration cannot recover to atmosphere oxygen concentration ● Flowmeter of oxygen sensor is blocked ● Pump failure ● Filter degraded or blocking ● Oxygen sensor failure ● Oxygen sensor board failure 	<ul style="list-style-type: none"> ● Use gas pipe switching valve, connect the test port of oxygen concentration meter to atmosphere directly. See P.40 picture. ● Replace the flowmeter ● Replace ● Replace the filter ● Replace ● Replace
Thermo regulator failure	<ul style="list-style-type: none"> ● Defective display function ● Sensor failure 	<ul style="list-style-type: none"> ● Maintain or replace the part. ● Replace the part.
Blower adjusting dial is defective.	<ul style="list-style-type: none"> ● Adjusting circuit failure and wiring failure ● Lack of capacity of heater due to excessive circulating airflow ● The adjusting dial for ADL311S or GB210A is being used 	<ul style="list-style-type: none"> ● Maintain the part or replace the thermo regulator. ● No error. For operating this unit with high temperature, decrease the flow rate of the circulating air or increase the setting value ● When the unit is connected to GAS410, operate the dial on the GAS410 side. (Dial for ADL311S or GB210A is disabled.)

- ◆ In the case if the error other than listed above occurred, turn off the power switch and primary power source immediately. Contact the shop of your purchase or nearest Yamato Scientific Service Office.



8. In the Event of Failure...

Trouble Shooting

- ※ When the value of oxygen concentration monitor cannot recover beyond 18% after operation, it's suspected that it may be influenced by active carbon filter absorption, operate as per the following pictures. Adjust the gas pipe switching valve to connect to atmosphere (External gas), wait for several minutes, and check if the oxygen concentration display recovers beyond 18%. After confirmation, make reverse operation to recover the working state (Internal gas).

Open the access door at left side



Turn the gas pipe switching valve from  to 

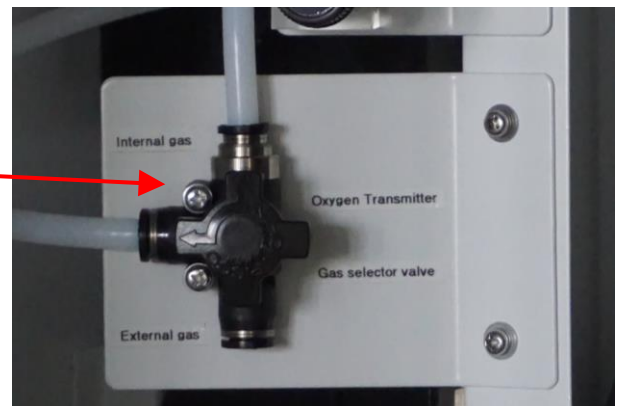

9. After Service and Warranty

When requesting a repair

When requesting a repair

If any trouble occurs, immediately stop operation, turn the power switch off, pull out the power plug and contact your dealer, our sales office or our customer service center.

Information necessary for requesting a repair

- Model name of the product
 - Serial number
 - Date (y/m/d) of purchase
 - Description of trouble (as in detail as possible)
- } See the warranty card or the nameplate on the unit.
} See the section "3.Names of parts and their function" on page 8.

Be sure to indicate the warranty card to our service representative.

Warranty card (attached separately)

- Warranty card is given by your dealer or one of our sales offices and please fill in your dealer, date of purchase and other information and send it to our customer service center by Facsimile (03-3231-6523). Then, store it securely.
- Warranty period is one full year from the date of purchase. Repair service for free is available according to the conditions written on the warranty card.
- For repairs after the warranty period consult your dealer, one of our sales offices or our customer service center.
Paid repair service is available on your request when the product's functionality can be maintained by repair.

Minimum holding period of repair parts

The minimum holding period of repair parts for this product is seven years after end of production. Repair parts here refer to parts necessary for maintaining performance of the product.

10. Specifications

Specification of the main unit

System	Sealed circulation type
Circulating gas	N ₂ gas
Circulating amount	0.12~0.65m ³ /min
Solvent recovery system	Capacitor(cooling trap) +freezer
Fine dust collecting system	Cartridge filter
Circulating blower	Roots blower
Solvent collecting container	2L flask
Indicators	Trap temperature, oxygen concentration
Meters	Filter differential pressure meter, flow meters (for introducing N ₂ , for the oxygen sensor)
Filter	For protecting the O ₂ sensor
Pump	For circulation for measuring oxygen concentration
Compressor	For pushing the spray nozzle
Safety device	Oxygen concentration meter, flammable gas alarm
Power supply	Single phase 200-240V~ 5-6A
External dimensions (mm) ※1 (WxDxH)	710x950x1450
Weight	Approx.130kg
Accessories	<ul style="list-style-type: none"> · Specimen tube Silicone: I.D. 2 mm×O.D. 4 mm×1m 2 <li style="padding-left: 20px;">Viton: I.D. 2 mm×O.D.4 mm×1m 2 · Bellows: 40KF L=1300 1 · Bellows: 40KF L=1000 1 · Clamp 40KF 4 · O-ring 40KF 4 · Duct hose φ25×2m 1 · Hose band TM-144SUS №5713 1 · Tetrone braided hose φ6×φ11×5m 1 · Tetrone braided hose φ6×φ11×1.5m 1 · Fluoro-rubber tube E-PD-6 φ6×φ9 1.5m 1 · Hose band TM145-SUS No.5956 6 · Connector RNJC-PFPM-20-12-A-1 2 · 2L collecting flask GAS41-30330 1 · Flask clamp KS35 1 · Tube GAS410_01_02_05 1 · Screw M4×10 SUS 3 · Warranty card 1 · Operating manual GAS410 1 · Filter element neal 2

※1 External dimensions do not include protruding parts.

11. Wiring diagram

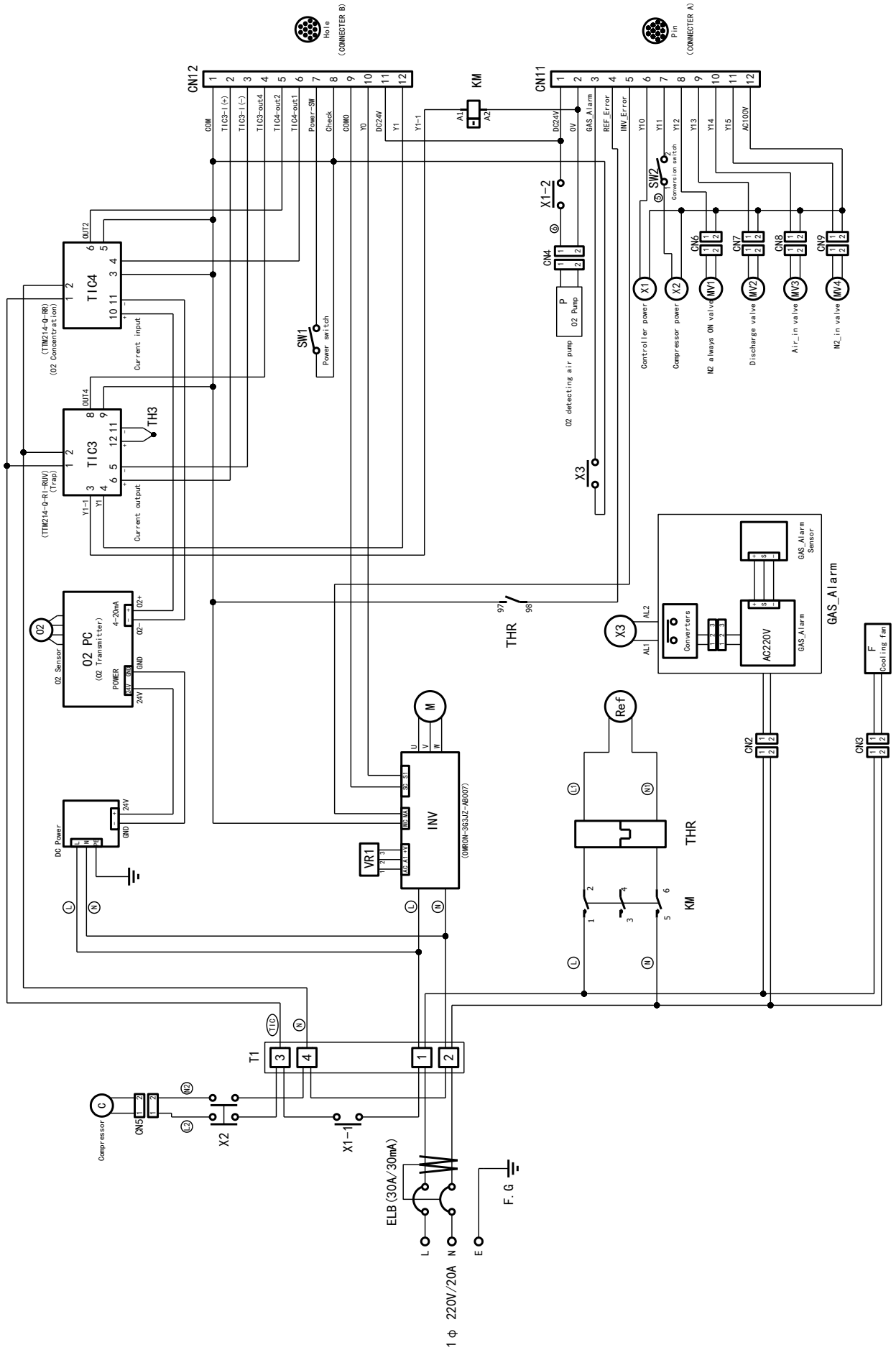

12. Replacement parts table

	Part name	Standard	Manufacturer	Code №
※	Filter	GAS41-40040 For freezer	YSC	B040300003
	Gas alarm	TJ-PLT119-EX	YSJ	A020299002
	ELB	BV-DN 1P+N 10A 30mA	YSJ	A010410007
	Cooling fan	SJ1238HA2BAL	YSJ	A080104012
	Freezer unit	CAJ2428ZBR	YSJ	A030101001
	Temperature sensor	GAS410C_03_01-01	YSJ	H100101001
	Roots blower	IRS-32A	YSJ	B040201001
※	Pump	D35S-41J-0000 for oxygen sensor	YSJ	A041400055
※	Activated charcoal filter set	GAS41-40570 for oxygen sensor	YSC	B081601001
	Flow meter	LZB-07A10MT 5-50L/min	YSJ	A040409005
	Flow meter	LZM-6T 0.1-1.5L/min	YSJ	A040499023
	Solenoid valve	CKD AB41-04-8-M-AC100V for suctioning	YSJ	A040403015
	Solenoid valve	CKD AB41-03-7-F-AC100V for discharging	YSJ	A040403014
	Solenoid valve	CKD AB31-01-2-M-AC100V for introducing N ₂	YSJ	A040403013
	Solenoid valve	CKD AB41-02-5-F-AC100V for controlling N ₂	YSJ	A040403004
	Linear compressor	AC0910	YSC	B030200001
	Differential pressure meter	DG87-641-1C 0~1kPa	YSC	B042300001
※	Filter element	RE-205-90-FB 0.3μ	YSC	B040300001
※	Fluoro rubber tube	φ4×φ6 specify length	YSC	B080807049
※	Teflon tube	φ6×φ8 specify length	YSJ	A080807007
※	Teflon tube	φ10×φ12 specify length	YSJ	A080807006
	Bellows	40KF L=160	YSJ	A041500019
	Bellows	40KF L=1500	YSJ	A041500006
	Bellows	40KF L=1000	YSJ	A041500003
	Bellows	40KF L=500	YSJ	A041500008
	Bellows	40KF L=1300 for external connection	YSJ	A041500004
	Bellows	40KF L=1000 for external connection	YSJ	A041500003
	Clamp	40KF	YSJ	A041500078
※	Center ring	40KF	YSJ	A041500077
	Duct hose	Nominal size:25×2m	YSC	B080807030
※	Tetlone braided hose	φ6×φ11 specify length	YSC	B080807028
※	Flexible fluoride tube	EPD-6φ6×φ9 specify length	YSC	B080807018
※	Liquid sending tube	GAS410C_01_03-05 Viton	YSJ	B080913005

12. Replacement parts table

	Part name	Standard	Manufacturer	Code №
※	Liquid sending tube	GAS410C_01_03-05 Silicone	YSJ	B080807050
	Temperature controller	TTM214-Q-RR for oxygen concentration display	YSC	B020101028
	Temperature controller	TTM214-Q-RI-RUV for trap display	YSC	B020101027
	Relay	HF13F/A1002Z1D	YSJ	A011002005
	Oxygen sensor module	HT-FX100	YSJ	A020799033
	DC Power	S8FS-C01524J	YSJ	A010801020
※	Filter element neal	130*130*0.5	YSJ	A089900040

Note: Parts marked with ※ are consumable parts.

13. List of Dangerous Substances



Never use explosive substances, flammable substances and substances that include explosive or flammable ingredients in this unit. Otherwise explosion or fire may result

Explosive substance	Explosive substance	①Nitroglycol, glycerine trinitrate, cellulose nitrate and other explosive nitrate esters
	Explosive substance	②Trinitrobenzen, trinitrotoluene, picric acid and other explosive nitro compounds
	Explosive substance	③Acetyl hydroperoxide, methyl ethyl ketone peroxide, benzoyl peroxide and other organic peroxides
Flammable substances	Explosive substances	Metal "lithium", metal "potassium", metal "natrium", yellow phosphorus, phosphorus sulfide, red phosphorus, celluloids, calcium carbide (a.k.a, carbide), lime phosphide, magnesium powder, aluminum powder, metal powder other than magnesium and aluminum powder, sodium dithionous acid (a.k.a., hydrosulphite)
	Oxidizing substances	①Potassium chlorate, sodium chlorate, ammonium chlorate, and other chlorates
		② Potassium perchlorate, sodium perchlorate, ammonium perchlorate, and other perchlorates
		③ Potassium peroxide, sodium peroxide, barium peroxide, and other inorganic peroxides
		④Potassium nitrate, sodium nitrate, ammonium nitrate, and other nitrates
		⑤Sodium chlorite and other chlorites
		⑥Calcium hypochlorite and other hypochlorites
	Flammable substances	①Ethyl ether, gasoline, acetaldehyde, propylene chloride, carbon disulfide, and other substances with ignition point at a degree 30 or more degrees below zero.
		② n-hexane, ethylene oxide, acetone, benzene, methyl ethyl ketone and other substances with ignition point between 30 degrees below zero and less than zero.
		③Methanol, ethanol, xylene, pentyl acetate, (a.k.a.amyl acetate) and other substances with ignition point between zero and less than 30 degrees.
		④Kerosene, light oil, terebinth oil, isopenthyl alcohol(a.k.a. isoamyl alcohol), acetic acid and other substances with ignition point between 30 degrees and less than 65 degrees.
	Combustible gas	Hydrogen, acetylene, ethylene, methane, ethane, propane, butane and other gases combustible at 15°C at one air pressure.

(Quoted from the separate table 1 in Article 6, the enforcement order of the Industrial Safety and Health Law)

Responsibility

Please follow the instructions in this document when using this unit. Yamato Scientific has no responsibility for the accidents or breakdown of device if it is used with a failure to comply. Never conduct what this document forbids. Unexpected accidents or breakdown may result in.

Note

- ◆ The contents of this document may be changed in future without notice.
- ◆ Any books with missing pages or disorderly binding may be replaced.

Instruction Manual
Solvent Recovery Unit
GAS410

Version 1 Dec. 16, 2013

Revision Mar. 11, 2025

YAMATO SCIENTIFIC CO., LTD.
Harumi Triton Square Y-36F, 1-8-11 Harumi,
Chuo-ku, Tokyo 104-6136, Japan
Tel : +81-3-5548-7122
Fax : +81-3-5548-0132
<https://www.yamato-scientific.com/>