

SINCE 1889



Constant High Temperature Water Bath

Model BK310C BK410C
BK510C BK610C
BK710C

First Edition

- Thank you for purchasing "BK Series Constant High Temperature Water Bath" of Yamato Scientific Co., Ltd.
- To use this unit properly, read this "Instruction Manual" thoroughly before using this unit. Keep this instruction manual around this unit for referring at any time.

⚠ WARNING!

Carefully read and thoroughly understand the important warning items described in this manual before using this unit.

Yamato Scientific Co.,Ltd.

1. Cautions in using with safety	1
Explanation	1
Table of Illustrated Symbols	2
Fundamental Matters of "WARNING!" and "CAUTION!"	3
2. Before using this unit	4
Requirements for Installation	4
3. Name and Function of Each Part	8
Main Unit	8
Operation panel	9
Characters of the Controller	10
4. Operation Method	12
Operation Mode and Function List	12
Operation Mode, Function Setting Key, and Characters	14
Setting of Overheating Prevention Device	15
Fixed Temperature Operation	16
Quick Auto Stop Operation	17
Auto Stop Operation	19
Auto Start Operation	21
Other Functions	23
5. Handling Precautions	25
6. Maintenance Method	27
Daily Inspection and Maintenance	27
7. Long storage and disposal	28
When not using this unit for long term / When disposing	28
Disposal Notice	28
8. In the Event of Failure	29
Safety Device and Error Code	29
Trouble Shooting	30
9. After Service and Warranty	31
When requesting a repair	31
10. Specification	32
11. Wiring Diagram	33
12. Replacement Parts Table	35
13. List of Dangerous Substances	37
14. Installation Manual	38

1. Cautions in using with safety

Explanation

MEANING OF ILLUSTRATED SYMBOLS

Illustrated Symbols

Various symbols are used in this safety manual in order to use the unit without danger of injury and damage of the unit. A list of problems caused by ignoring the warnings and improper handling is divided as shown below. Be sure that you understand the warnings and cautions in this manual before operating the unit.

 **WARNING!** If the warning is ignored, there is the danger of a problem that may cause a serious accident or even fatality.

 **CAUTION!** If the caution is ignored, there is the danger of a problem that may cause injury/damage to property or the unit itself.

Meaning of Symbols



This symbol indicates items that urge the warning (including the caution).
A detailed warning message is shown adjacent to the symbol.



This symbol indicates items that are strictly prohibited.
A detailed message is shown adjacent to the symbol with specific actions not to perform.



This symbol indicates items that should be always performed.
A detailed message with instructions is shown adjacent to the symbol.

1. Cautions in using with safety

Table of Illustrated Symbols

Warning



Warning,
generally

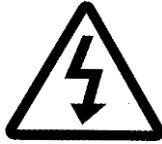

Warning,
high voltage



Warning,
high temperature



Warning,
drive train



Warning,
explosive

Caution



Caution,
generally



Caution,
electrical shock



Caution,
scald



Caution,
no load heating



Caution,
not to leak



Caution,
water only



Caution,
deadly poison

Prohibit



Prohibit,
generally



Prohibit,
inflammable



Prohibit,
to disassemble



Prohibit,
to touch

Compulsion



Compulsion,
generally



Compulsion,
connect to the
grounding
terminal



Compulsion,
install on a flat
surface



Compulsion,
disconnect the
power plug



Compulsion,
periodical
inspection

1. Cautions in using with safety

Fundamental Matters of "WARNING!" and "CAUTION!"

Warning

Do not use this unit in an area where there is flammable or explosive gas

Never use this unit in an area where there is flammable or explosive gas. This unit is not explosion-proof. An arc may be generated when the power switch is turned on or off, and fire/explosion may result. (Refer to page 37 "13. List of Dangerous Substances".)

Always ground this unit

Always ground this unit on the power equipment side in order to avoid electrical shock due to a power surge.

If a problem occurs

If smoke or strange odor should come out of this unit for some reason, turn off the power key right away, and then turn off the circuit breaker and the main power. Immediately contact a service technician for inspection. If this procedure is not followed, fire or electrical shock may result. Never perform repair work yourself, since it is dangerous and not recommended.

Do not use the power cord if it is bundled or tangled

Do not use the power cord if it is bundled or tangled. If it is used in this manner, it can overheat and fire may be caused.

Do not process, bend, wring, or stretch the power cord forcibly

Do not process, bend, wring, or stretch the power cord forcibly. Fire or electrical shock may result.

Substances that cannot be used

Never use explosive substances, flammable substances and substances that include explosive or flammable ingredients in this unit. Explosion or fire may occur. (Refer to page 37 "13. List of Dangerous Substances".)

Do not touch high-temperature parts

The inside of the body or the door may become hot during and just after operation. It may cause burns.

Do not disassemble or modify this unit

Do not disassemble or modify this unit. Fire or electrical shock or failure may be caused.

Caution

During a thunder storm

During a thunderstorm, turn off the power key immediately, then turn off the circuit breaker and the main power. If this procedure is not followed, fire or electrical shock may be caused.

2. Before using this unit

Requirements for Installation

Warning

1. Always ground this unit



BK310C/BK410C/BK510C/BK610C/BK710C does not have power plug, uses single phase 220V power source and needs power cord connecting work, please consult your local electrical contractor for power connecting work, grounding as per electrical device technical benchmark.



- Be sure to connect the earth wire (the green cable of power cord) to the grounding conductor or ground terminal to prevent accidents caused by electric leakage.
- Do not connect the earth wire to gas or water pipes. If not, fire disaster may be caused.
- Do not connect the earth wire to the ground for telephone wire or lightning conductor. If not, fire disaster or electric shock may be caused.
- Do not use a branching receptacle, which may cause the heat generation.

Better to use grounding socket

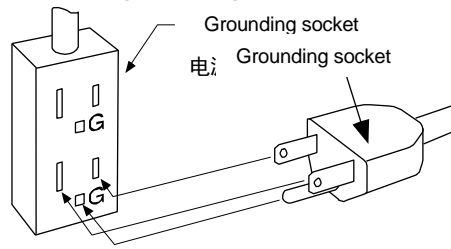

2-pole socket

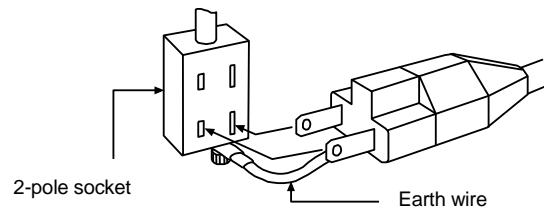

No grounding terminal

- Need power connecting work, please consult your local electrical contractor or Yamato Business Office.

- Insert the grounding adaptor to power plug, confirm the socket polarity and connect. In addition, connect the earth wire (green) of grounding adaptor with grounding terminal of power unit.

2. Choose a proper place for installation



Do not install this unit in a place where:

- ◆ Rough or dirty surface.
- ◆ Flammable gas or corrosive gas is generated.
- ◆ Ambient temperature exceeds 35°C.
- ◆ Ambient temperature fluctuates violently.
- ◆ There is direct sunlight.
- ◆ There is excessive humidity and dust.
- ◆ There is a constant vibration.



Install this unit on a stable place with the space as shown below.

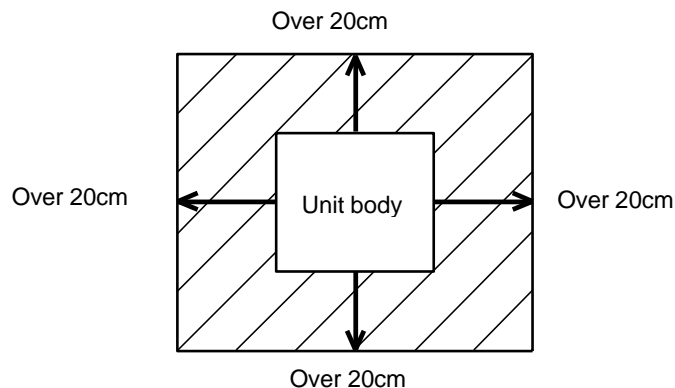

2. Before using this unit

Requirements for Installation



Warning

3. Do not use this unit in an area where there is flammable or explosive gas

(Refer to page 37 "13. List of Dangerous Substances".)

- ⊘ Never use this unit in an area where there is flammable or explosive gas. This unit is not explosion-proof. An arc may be generated when the power switch is turned ON or OFF, and fire/explosion may result.



fire/explosion may result.

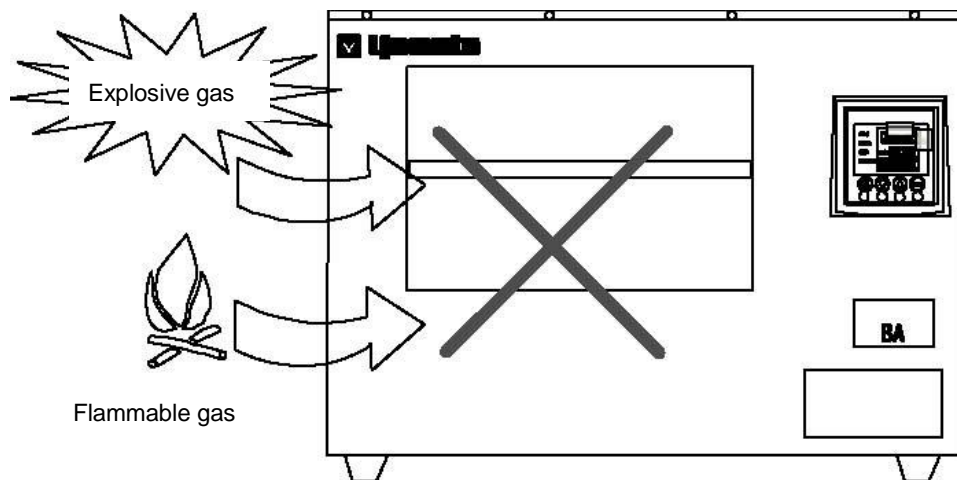

- ⊘ Never use explosive substances, flammable substances and substances that include explosive or flammable ingredients in this unit. Explosion or fire may occur.

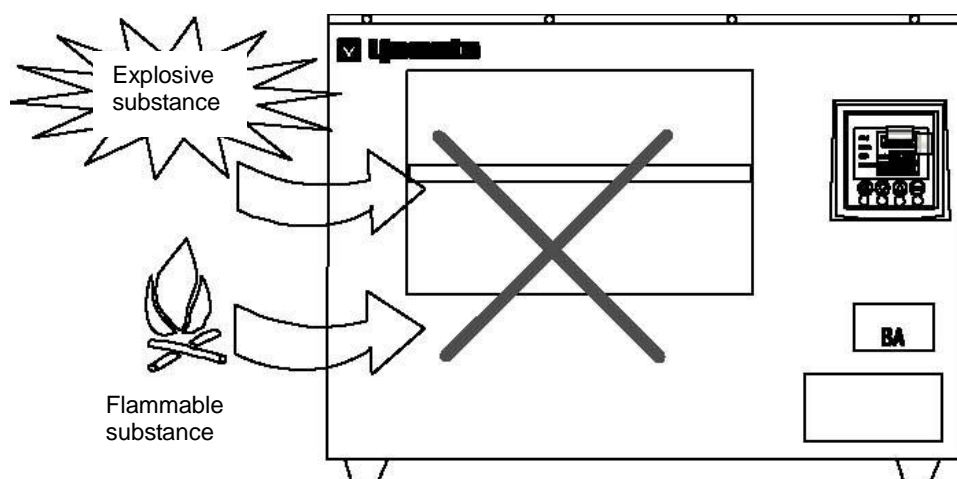

2. Before using this unit

Requirements for Installation

Warning

4. Do not modify



Modification of this unit is strictly prohibited. This could cause a failure.

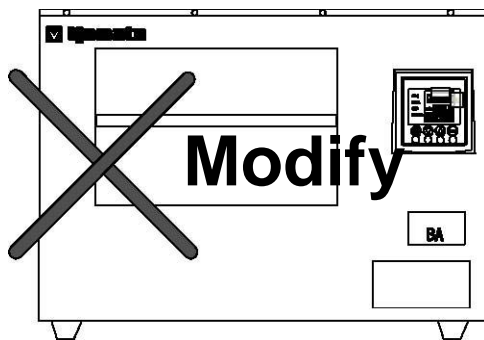

5. Installation on horizontal surface



Set this unit to the flattest place. Setting this unit on rough or slope place could cause the vibration or noise, or cause the unexpected trouble or malfunction.

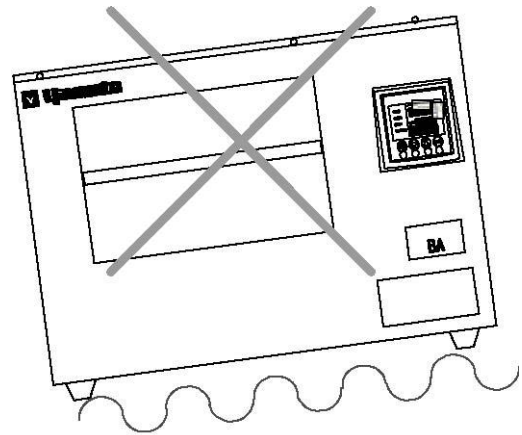

6. Please exhaust the air in the circulating pump



- Due to different water inflow ways, the circulating pump of unit body may have residual air and result in idling of circulating pump, which would make strident noise and cause equipment damage. Please according to the following main points, exhaust the air in the circulating pump when draining water.
- • During the process of injecting water into the hidden circulating pump water inlet and outlet, connect the water inflow hose with water inlet to inject water while exhausting the air through water outlet.
- • During the process of injecting water into the hidden circulating pump water inlet and outlet, tilt the unit body to exhaust the air through water outlet.

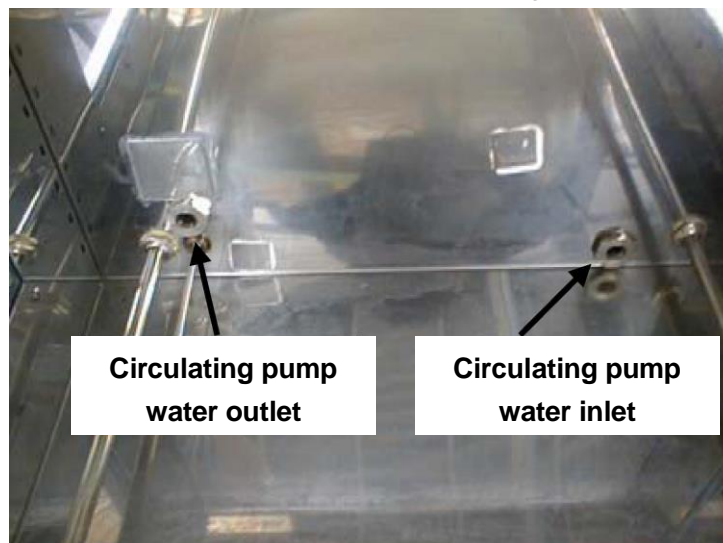

2. Before using this unit

Requirements for Installation



Caution

7. Choose a correct socket



Choose a correct power socket that meets the unit's rated electric capacity.

Electric capacity	BK310C	AC220V	6A	BK610C	AC220V	16.5A
	BK410C	AC220V	10.5A	BK710C	AC220V	21A
	BK510C	AC220V	11.5A			

There could be the case that the unit does not run even after turning ON the power. Inspect whether the voltage of the main power is lowered than the specified value, or whether other device(s) uses the same power line of this unit. If the phenomena might be found, change the power line of this unit to the other power line. When BK610C/BK710C does not have plug, please consult your dealer or a local electrical contractor for the connection of devices that use a single-phase 220V power source.

9. Installation and layout



It may cause injure to a person if this unit falls down or moves by the earthquake and the impact. etc.. To prevent, take measures that the unit cannot fall down, and not install at a busy place.

10. Handling of power cord



- Do not entangle the power cord. This will cause overheating and possibly a fire.
- Do not bend or twist the power cord, or apply excessive tension to it. This may cause a fire and electrical shock.
- Do not lay the power cord under a desk or chair, and do not allow it to be pinched in order to prevent it from being damaged and to avoid a fire or electrical shock.



- Keep the power cord away from any heating equipment such as a room heater. The cord's insulation may melt and cause a fire or electrical shock.
- If the power cord becomes damaged (wiring exposed, breakage, etc.), immediately turn off the power at the rear of this unit and shut off the main supply power. Then contact your nearest dealer for replacement of the power cord. Leaving it may cause a fire or electrical shock.
- Connect the power plug to the receptacle which is supplied appropriate power and voltage.

3. Name and Function of Each Part

Main Unit

BK310C/410C/510C/610C/710C

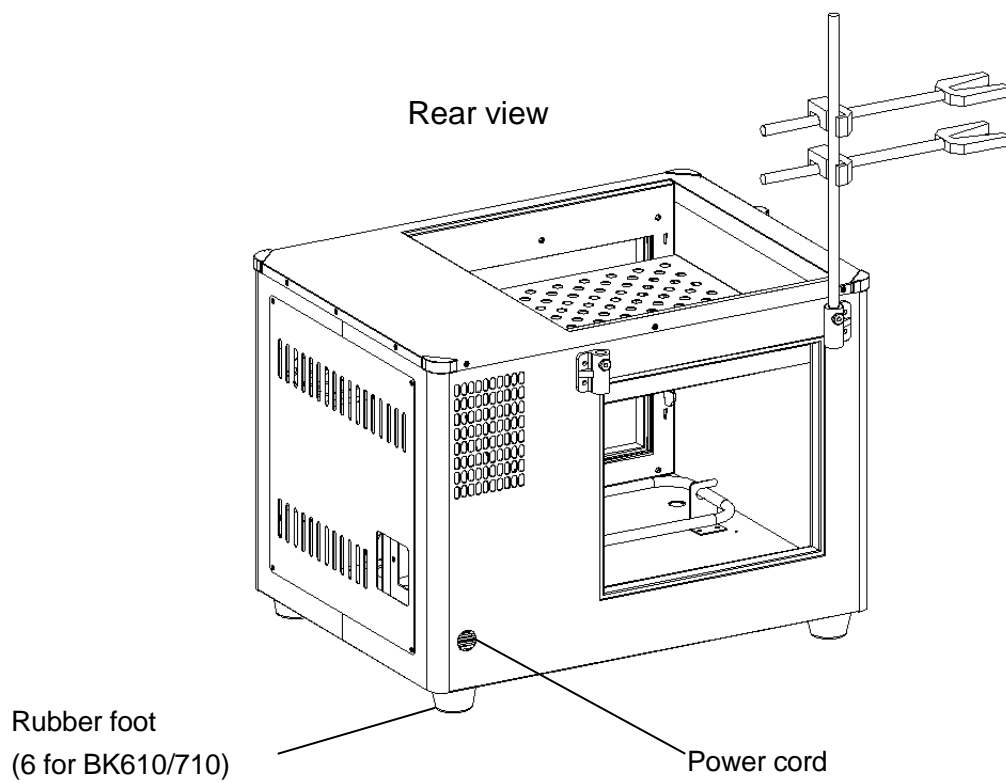
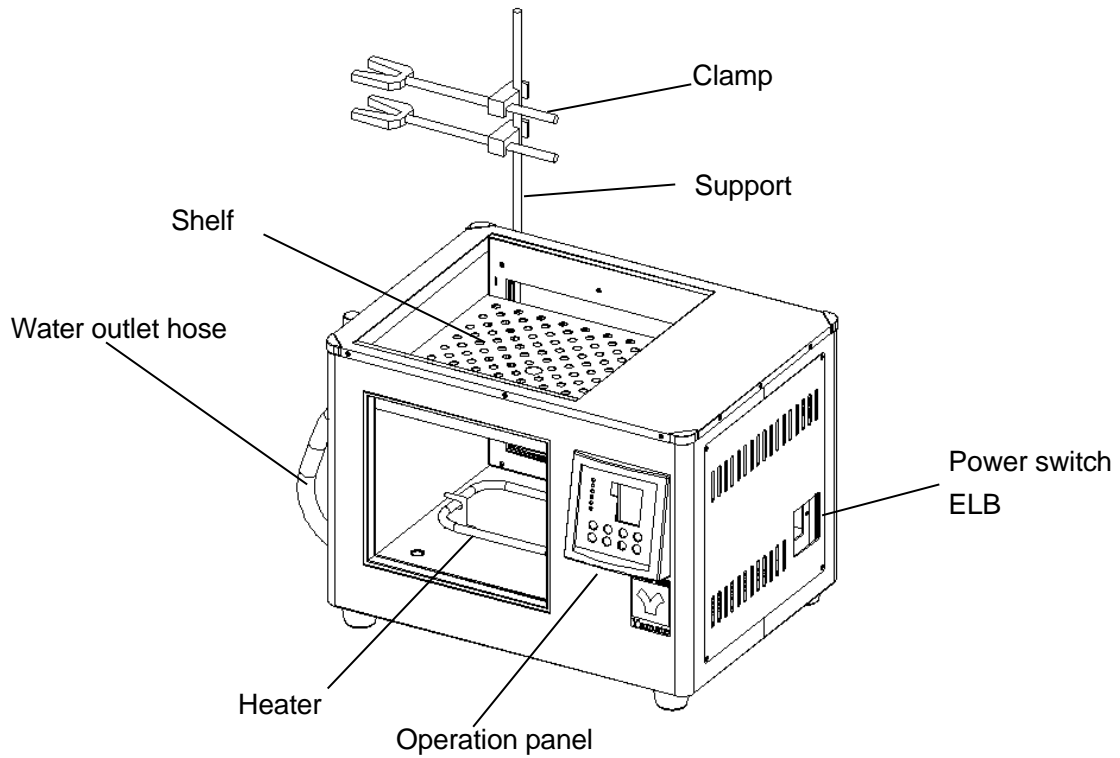

3. Name and Function of Each Part

Operation panel

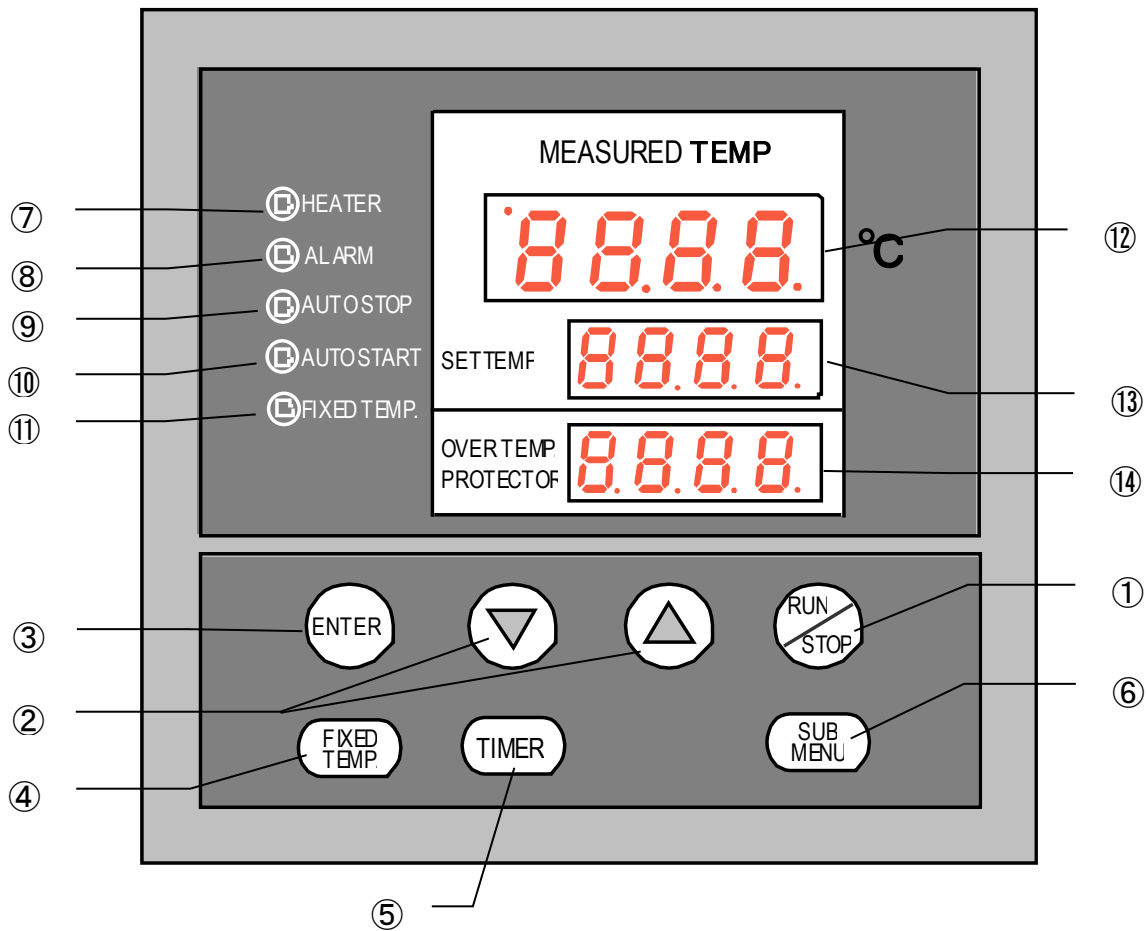







①	RUN/STOP key	Used for starting/stopping operation.
②	▲▼ Key	Uses for rising UP/lowering DOWN the setting value.
③	ENTER Key	Settles the inputted value.
④	FIXED TEMP Key	Chooses the fixed temperature operation.
⑤	TIMER Key	Chooses the timer operation (Quick Auto Stop/Auto Stop/Auto Start).
⑥	SUBMENU Key	Uses for setting the overheating prevention temperature, calibration offset temperature, key lock function, or program repeat function.
⑦	HEATER Lamp	Lights while the heater works.
⑧	ALARM Lamp	Lights up when an error occurs. (Buzzer sounds simultaneously.)
⑨	AUTO STOP Lamp	Blinks while setting quick auto stop timer or auto stop timer. Lights while quick auto stop timer or auto stop timer is running.
⑩	AUTO START Lamp	Blinks while setting auto start timer. Lights while auto start timer is running.
⑪	FIXED TEMP Lamp	Blinks while setting fixed temperature operation. Lights while fixed temperature operation is running.
⑫	Measurement Temp. Display	Displays the measured temperature, setting character, alarm information.
⑬	Setting Temp. Display	Displays the setting temperature, setting value for timer mode, remaining time.
⑭	Overheating Prevention Temp. Display	Displays the setting temperature for overheating prevention device.

3. Name and Function of Each Part



Characters of the Controller

The explanation of VS6 controller characters are as follows:

Character	Identifier	Name	Purpose
	Fix	Fixed Temperature Setting Mode	Used for starting the fixed temperature operation.
	Sv	Temperature Setting	Used for setting the temperature.
	AStP	Timer Setting Mode Display	Represents the setting of quick auto stop or auto stop operation.
	AStr	Timer Setting Mode Display	Represents the setting of auto start operation.
	tim	Time Setting	Used for setting the time.
	End	Time Up	Displays when the timer operation is completed (Refer to Page 17, 20)

3. Name and Function of Each Part

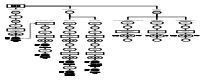
Characters of the Controller

Character	Identifier	Name	Purpose
	cAL	Calibration Offset Setting	Used for inputting the calibration offset temperature. (Refer to Page 23 "Other Functions".)
	oH	Overheating Prevention Setting	Used for setting temperature for overheating prevention device. (Refer to Page 15 "Setting of Overheating Prevention Device".)
	Lock	Key Lock	Locks the keys on control panel to protect from unnecessary operation. (Refer to Page 24 "Other Functions".)

※ Also refer to Page 14 "Operation Mode, Function Setting Key, and Characters".

※ The operation mode cannot be changed during operation. If need to change the mode, conduct after operation stop.

4. Operation Method

Operation Mode and Function List

All the operation modes of this unit are as below:

No.	Name	Description	Page
1	Fixed Temperature Operation	Pressing the FIXED TEMP. key to enter the Fixed temperature operation setting mode. Pressing the FIXED TEMP. key again to enter the temperature setting mode. Set a temperature with the ▼▲ keys. Pressing the RUN/STOP key to start operation, and pressing the RUN/STOP key again to stop operation.	P.16
2	Quick Auto Stop Operation	Used when you want to “stop fixed temperature operation being performed automatically in several hours.” Pressing the TIMER key during the fixed temperature operation to enable setting a time before operation stops. Set duration before stop with the ▼▲ keys. Pressing the RUN/STOP key starts quick auto stop operation and activates the timer in the middle of it to automatically stop it after the set period of time.	P.17
3	Auto Stop Operation	Used when you want to “set automatic stop for fixed temperature operation when making settings for it.” Press the TIMER key to display “AStP.” Pressing the ENTER key to set the temperature setting “Sv.” Pressing the ENTER key again to enable setting of the operation time “tim.” Pressing the RUN/STOP key starts auto stop operation.	P.19
4	Auto Start Operation	Used when you want to “start operation automatically after several hours” after power is turned on. Press the TIMER key to display “AStr.” Pressing the ENTER key to set the temperature setting “Sv.” Pressing the ENTER key again to enable setting of the operation time “tim.” Pressing the RUN/STOP key starts auto start operation.	P.21
<p>※ This unit is impossible to be changed the mode during the operation. If the mode requires to be changed, stop the operation.</p>			

4. Operation Method

Operation Mode and Function List

The operation functions of this unit are as below:

No.	Name	Description	Page
1.	Overheat prevention function	<p>Automatic overheat prevention function:</p> <p>This function is linked to the unit set temperature and has been set to so that it is automatically activated (returned automatically) at a temperature 6°C higher than the set temperature in the bath.</p> <p>Overheat prevention device:</p> <p>Although the power supply, the display and the key input assembly are in common with the controller, the device consists of the standalone temperature measurement circuit, the CPU, the sensor, and the output circuit enabling to set to a temperature you want on the operation panel.</p> <p>If the overheat prevention device is triggered, the unit will stop and will not recover until the ELB is turned on again. (Manual recovery)</p> <p>This compensation can be set with the SUB MENU keys.</p>	P. 15
2.	Calibration offset function	<p>Calibration offset function compensates any differences between the target temperature in the bath and the control temperature of the controller (sensor temperature.)</p> <p>The function can compensate to either plus or minus side for the whole temperature band of the unit.</p> <p>This compensation can be set with the SUB MENU keys.</p>	P. 23
3.	Setting lock function	<p>This function locks the set operation status.</p> <p>The lock can be set or released with the SUB MENU key.</p>	P. 24
4.	Power outage compensation function	<p>When power outage occurs in the middle of operation, the operation resumes from the settings immediately before the power outage.</p>	-

4. Operation Method

Operation Mode, Function Setting Key, and Characters

The operation mode setting and function setting use the key operation and characters show in the following figure.

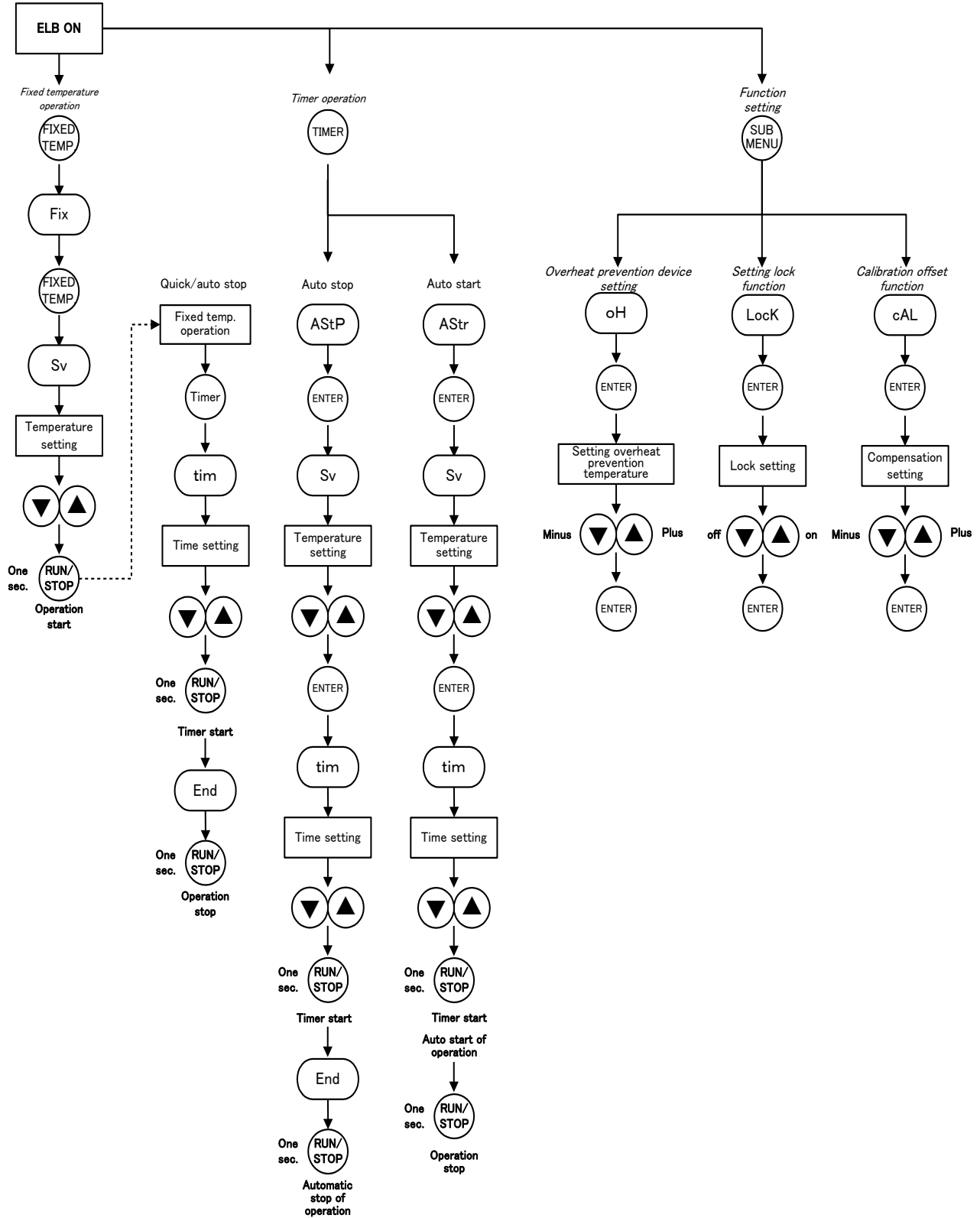

4. Operation Method

Setting of Overheating Prevention Device

The unit has the overheating prevention device (manual reset) that consists of independent temperature measurement circuit, CPU, sensor and output circuit (it shares power source, display, and key input with the controller) in addition to the automatic overheating prevention function (auto reset) in the controller.

Setting range/function

The unit has failsafe functions against overheating. One of them is built in the controller and previously set at factory shipment so to be automatically activated when the temperature exceeds the setting temperature of temperature controller by 6°C, where the heater repeats on and off.

The other is united with the controller, which can be set by operating the keys on the controller.

The setting range of latter is from 0°C to max set temperature of main controller + 50°C.

In case the temperature in furnace exceeds the setting temperature of controller to reach to that of overheating prevention device, the circuit is shut off and "Er19" is displayed with blinking on the screen of controller with buzzer sound. If the device is once activated, "Er19" continues to be displayed until the power is newly turned on.

Temperature setting procedure

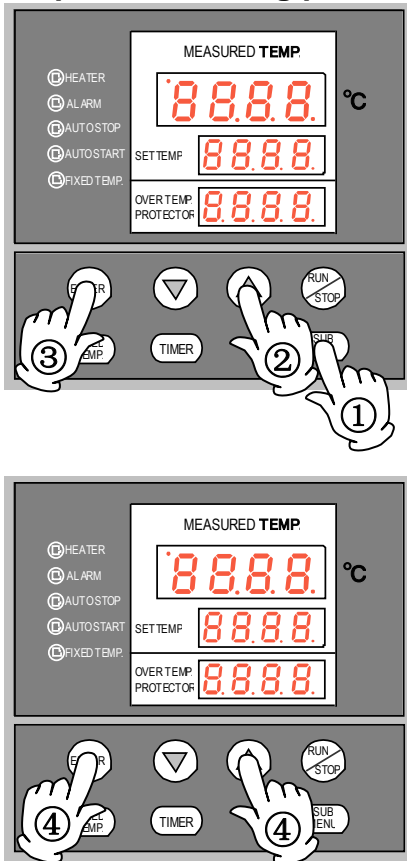

1. Turn on the power (turn on the ELB)

The default value is displayed for about four seconds after turning on the power. The screen then displays the initial setting. The current temperature in furnace, operation mode character and setting temperature of overheating prevention device are displayed on respective screens.

2. Set the temperature for overheating prevention

- 1 Press the **SUB MENU** key.
- 2 Press the "▼▲" several times to select the setting character of overheating prevention temperature "OH" .
- 3 Press the **ENTER** key. The current setting temperature is displayed with blinking on the setting temperature screen.

Note: To prevent improper operation, set the value 20°C or more over the setting temperature of controller.

- 4 Select the value using the "▼▲" and then press the **ENTER** key. This completes the setting.

Note

- 1 The standard setting temperature of device is "the maximum setting temperature of unit plus 10°C" or "setting temperature plus 10°C". If the unit performs improper operation, increase it 5°C more.
- 2 Improper setting of temperature may cause inoperative of unit, malfunction of device, e.g. it is activated during increasing in temperature in furnace, or unexpected accidents such as fire disaster. To prevent such matters, set a proper value.
The temperature is set to 90°C at factory shipment.
- 3 The purpose of overheating prevention device is to protect the unit from overheating. It does not intend to protect the samples, or to protect them from the accident caused by the use of explosive or inflammability.

4. Operation Method

Fixed Temperature Operation

Fixed temperature operation procedure

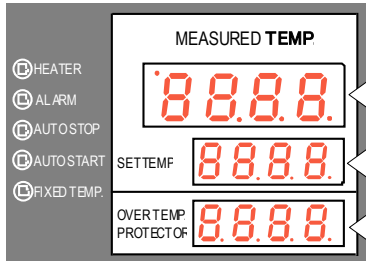

1. Turn on the power (turn on the ELB)

The default value is displayed for about four seconds after turning on the power. The screen then displays the initial setting. The current temperature in furnace, operation mode character and setting temperature of overheating prevention device are displayed on respective screens.

Measurement temperature screen: Displays the current temperature in furnace.

Setting temperature screen: Displays the operation mode character. (Refer to Page 14)

Overheating prevention screen: Displays the setting temperature of overheating prevention device

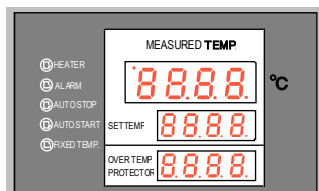

2. Select the operation mode

Press the **FIXED TEMP** key to display "FIX", which indicates the fixed temperature operation, on the center display screen.

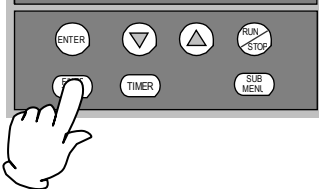

3. Set the temperature

- Press the **FIXED TEMP** key again.
- The setting temperature screen displays the character "SV" which indicates the temperature setting. Also it displays the current setting temperature with blinking. The FIXED TEMP lamp blinks, too.
- Set the temperature by pressing the "▼▲".

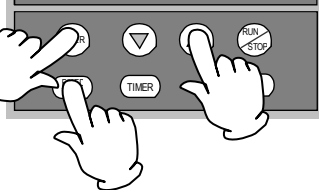
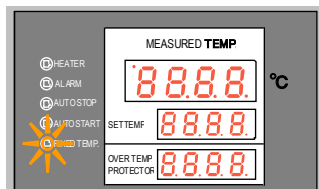

4. Start operation

Press the orange **RUN/STOP** key for about one second. The unit starts operation and the blinking FIXED TEMP lamp lights on.

5. Stop operation

Press the orange **RUN/STOP** key for about one second. The unit stops operation and the FIXED TEMP lamp lights off. The screen returns to the initial setting screen.

To correct or check setting...

Press the **FIXED TEMP** key again to correct or check the setting.

Changing the setting temperature during operation is also possible by pressing the **FIXED TEMP** key.

4. Operation Method

Quick Auto Stop Operation

Quick auto stop operation procedure

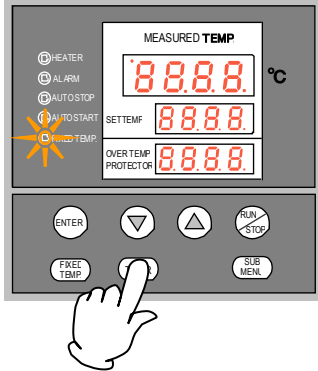

This operation is used to specify the period up to automatic stop, i.e., sets the auto stop timer during operation.

1. Set the time up to stop during fixed temperature operation

- Check that the FIXED TEMP lamp lights on and that the unit is under operation.
- Press the **TIMER** key.
- The measurement temperature display screen displays the character "tim", which indicates the timer setting. The setting temperature display screen displays the current setting time with blinking.
- Select the time by pressing the "▼▲".

Timer function:

- The maximum setting time is "999hours and 50 minutes".
- The time can be set in increments of a minute under 99 hours and 59 minutes.
- It can be set in increment of ten minutes over 100 hours.
- The "▼▲" can change the setting time quickly when it is pressed continuously. Press them discontinuously when fine adjustment is needed.

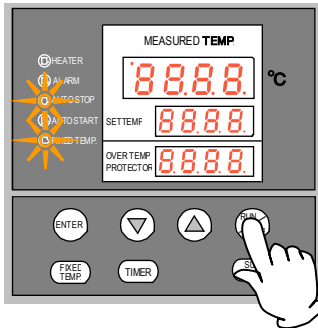

2. Start timer operation

- Press the **RUN/STOP** key for one second after deciding the time.
- Timer operation starts with the FIXED TEMP and AUTO STOP lamps lighting on.
- The timer is activated at the point when the **RUN/STOP** key is pressed.

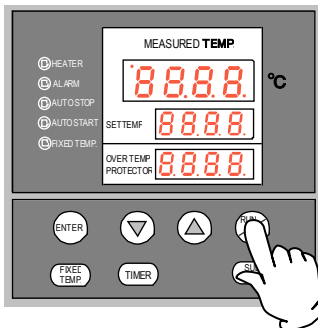

3. Stop/terminate timer operation

- The operation stops automatically at setting time.
- Buzzer continues to sound for about five minutes at operation stop.
- The setting temperature screen displays the character "End", which indicates termination of operation, with the FIXED TEMP and AUTO STOP lamps lighting on. Press the **RUN/STOP** key to terminate the timer operation mode. The screen returns to the initial setting screen.

4. Operation Method

Quick Auto Stop Operation

Change the set temp. and set time, confirm the set value

If need to change the set temp. during quick auto stop operation, press FIXED TEMP key to enter the setting mode.

If need to change the set time during quick auto stop operation, press TIMER key to enter the setting mode.

① After changing the time, press TIMER.
The remaining time on the timer is the time subtracting the elapsed time.
For example: set timer as 1hr30min, conduct quick auto stop operation, after 20min, change the set time to be 2hr, set it by TIMER, the remaining time is 1hr40min.

② After changing the time, press START/STOP for 1sec.
The quick auto stop operation proceeds again as per the changed time.
For example: set timer as 1hr30min, conduct quick auto stop operation, after 20min, change the set time to be 2hr, press START/STOP to set, the remaining time is 2hr.

Press ▼ key, switch over to display the set temp., operation mode and remaining time of set temp. displayer.

4. Operation Method

Auto Stop Operation

Auto stop operation procedure

This operation is used to specify the automatic stop time in the fixed temperature operation.

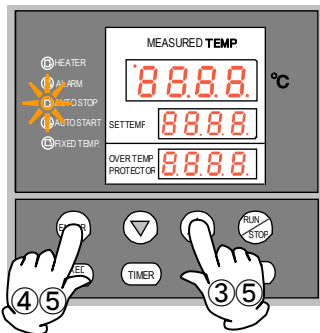
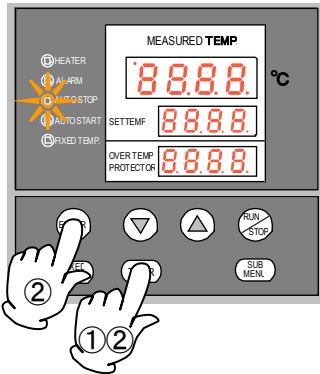

1. Set stop time

① Press the **TIMER** key on the initial screen.

Press the **TIMER** key again. The setting temperature display screen displays the character "AstP", which indicates the auto stop operation, with blinking.

② Press the **ENTER** key.

The measurement temperature screen displays the character "SV", which indicates the temperature setting. The setting temperature screen displays the current setting temperature with blinking. The AUTO STOP lamp blinks, too.

③ Set the temperature using the "▼▲".

④ Press the **ENTER** key again.

The measurement temperature display screen displays the character "tim", which indicates the timer setting. The setting temperature display screen displays the current setting time with blinking.

⑤ Set the time using the "▼▲".

Timer function:

- The maximum setting time is "999hours and 50 minutes".
- The time can be set in increments of a minute under 99 hours and 59 minutes.
- It can be set in increment of ten minutes over 100 hours.
- The "▼▲" can change the setting time quickly when it is pressed continuously. Press them discontinuously when fine adjustment is needed.

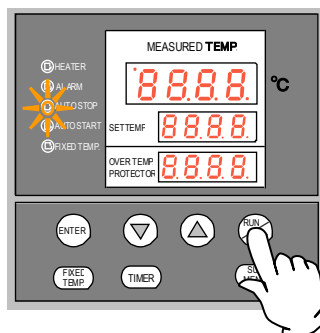

2. Start timer operation

• Press the **RUN/STOP** key for one second after deciding the time.

• Timer operation starts with the AUTO STOP lamp lighting on.

• The timer is activated at the point when the temperature in furnace (measurement temperature) reaches to the setting temperature.

4. Operation Method

Auto Stop Operation

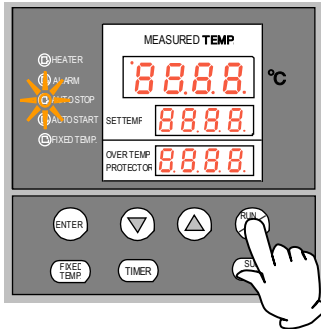

3. Stop/terminate timer operation

- The operation stops automatically at setting time.
- Buzzer continues to sound for about five minutes at operation stop.
- The setting temperature screen displays the character "End", which indicates termination of operation, with the FIXED TEMP and AUTO STOP lamps lighting on. Press the **RUN/STOP** key to terminate the timer operation mode. The screen returns to the initial setting screen.

To correct or check setting...

When you want change the set temperature or a set time, press the **TIMER** key during operation, set temperature and time for the auto stop operation with the **▼▲** keys and press the **ENTER** key to complete.

Note, however, when you change the set time you need to set a time calculated by adding the time already passed to the time to be added.

Pressing the **▼** key during operation will display the set temperature, the operation mode and the remaining time on the SET TEMP. display.

In terms of the remaining time display **1.30** a blinking dot indicates count down and an illuminating dot indicates a wait status (while temperature is increasing or decreasing to the set temperature) during which the timer has stopped counting.

4. Operation Method

Auto Start Operation

Auto start operation procedure

This operation is used to specify the period up to automatic start after power on.

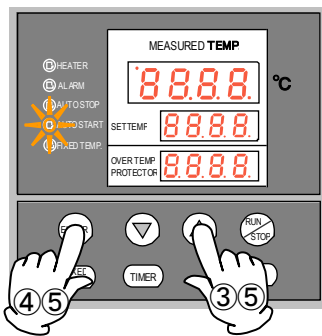
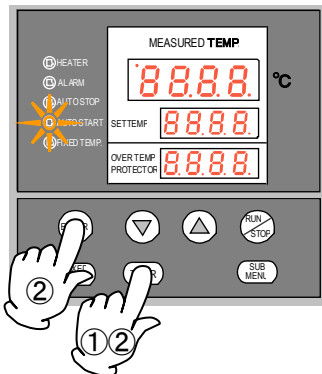

1. Set start time

- ① Press the **TIMER** key on the initial screen.
Press the **TIMER** key again. The setting temperature display screen displays the character "Astr", which indicates the auto start operation, with blinking.
- ② Press the **ENTER** key.
The measurement temperature screen displays the character "SV", which indicates the temperature setting. The setting temperature screen displays the current setting temperature with blinking. The AUTO START lamp blinks, too.
- ③ Set the temperature using the "▼▲".
- ④ Press the **ENTER** key again.
The measurement temperature display screen displays the character "tim", which indicates the timer setting. The setting temperature display screen displays the current setting time with blinking.
- ⑤ Set the time using the "▼▲".

Timer function:

- The maximum setting time is "999 hours and 50 minutes".
- The time can be set in increments of a minute under 99 hours and 59 minutes.
- It can be set in increment of ten minutes over 100 hours.
- The "▼▲" can change the setting time quickly when it is pressed continuously. Press them discontinuously when fine adjustment is needed.

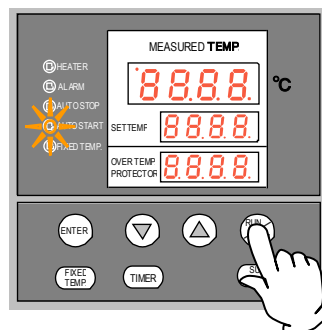

2. Start timer operation

- Press the **RUN/STOP** key for one second after deciding the time.
- Timer operation starts with the AUTO START lamp lighting on.

4. Operation Method

Auto Start Operation

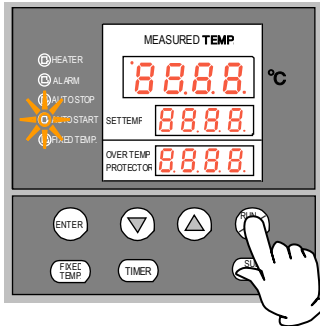

3. Stop/terminate timer operation

- The operation starts automatically at setting time.
- Press the **RUN/STOP** key for one second to stop or terminate operation. The screen returns to the initial setting screen.

To correct or check setting...

When you want change the set temperature or a set time, press the **TIMER** key during operation, set temperature and time for the auto start operation with the **▼▲** keys and press the **ENTER** key to complete.

Note, however, when you change the set time you need to set a time calculated by adding the time already passed to the time to be added.

Pressing the **▼** key during operation will display the set temperature, the operation mode and the remaining time on the SET TEMP. display.

When operation has started after the auto start time, you cannot change the set time. In this case, first stop operation with the **RUN/STOP** key and repeat all settings.

4. Operation Method

Other Functions

Use calibration offset function

Calibration offset is a function which corrects the difference between the temperature in furnace and that of controller (sensor temperature) if arises. The function parallel corrects the difference either to the plus or minus side within the whole temperature range of unit. The function can be set or cancelled by the **SUB MENU** key.

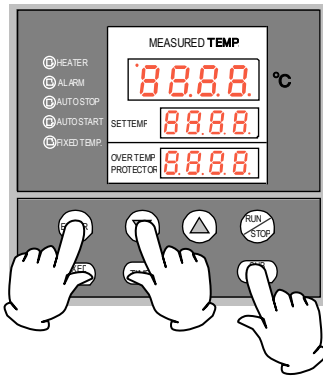
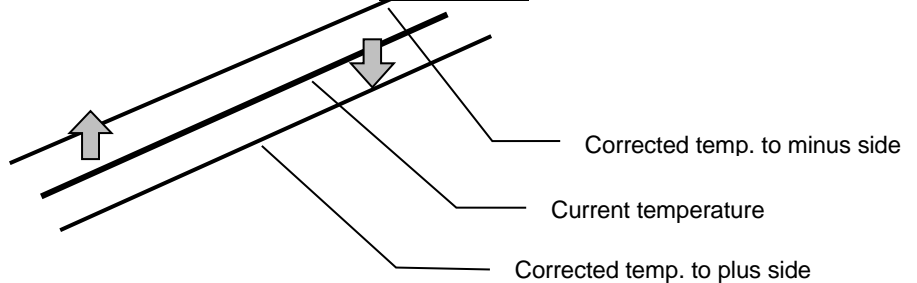

- ① Start operation with the target setting temperature. Check the temperature in furnace (temperature of sample) with a thermograph after it is stabilized.
 - ② Check the difference between the setting temperature and that in furnace (temperature of sample).
 - ③ Press the **SUB MENU** key. Select the character "cAL", which indicates the calibration offset, using the "▲▼", and then press the **ENTER** key.
 - ④ Input the difference using the "▲▼" and then press the **ENTER** key. This completes the setting.
- ❖ The setting range of offset correction temperature is +99°C to plus side and -99°C to minus side respectively.

When it is set to the minus side, the temperature on the measurement temperature display screen falls by the setting temperature, while the temperature on furnace rises.

When it is set to the plus side, the temperature on the measurement temperature display screen rises by the setting temperature, while the temperature on furnace falls.

- ❖ The unit has two-point correction function, which performs offset between low-temperature zone and high-temperature zone. Please consult our local branch office when carrying out validation of temperature controller.

4. Operation Method

Other Functions

Use lock function

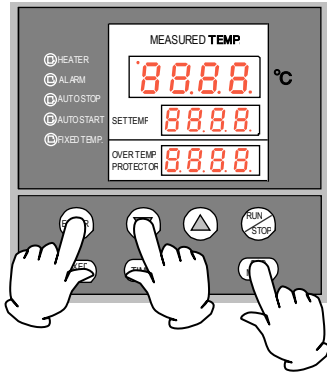

This function locks the operation status previously set. The function can be set or cancelled by the **SUB MENU** key.

① Press the **SUB MENU** key. Select the character "Lock", which indicates the lock of setting value, using the "▲▼", and then press the **ENTER** key.

② The setting temperature screen displays "oFF". The setting value is locked when it is turned to "on" using the "▲".

③ Press the **SUB MENU** key again to cancel the lock. Select the character "Lock", which indicates the lock of setting value, using the "▲▼", and then press the **ENTER** key. Select "oFF" with the "▼" and then press the **ENTER** key to cancel the function.

All keys other than the **RUN/STOP** and **SUB MENU** keys are locked when the lock function is on.

5. Handling Precautions

Warning

1. If a problem occurs

-  If smoke or strange odor should come out of this unit for some reason, turn off the power key right away, and then turn off the circuit breaker and the main power. Immediately contact a service technician for inspection. If this procedure is not followed, fire or electrical shock may result. Never perform repair work yourself, since it is dangerous and not recommended.

2. Substances that cannot be used

-  Never use explosive substances, flammable substances and substances that include explosive or flammable ingredients in this unit. Explosion or fire may occur. (Refer to page 37 "13. List of Dangerous Substances".)

Caution

1. Do not sit on this unit

-  Do not sit on this unit. It will cause injury if this unit falls down or breaks.

2. Do not put anything on this unit

-  Do not put anything on this unit. It will cause injury if fall.

3. During a thunder storm

-  During a thunderstorm, turn off the power key immediately, then turn off the circuit breaker and the main power. If this procedure is not followed, fire or electrical shock may be caused.

4. Please rinse thoroughly

-  Although this device has been rinsed thoroughly beforehand, when using it first time or not using for a long time, please rinse thoroughly.

5. About using water

-  ·Do not use other liquid except water.
·It's better to use ion exchange water or distilled water, and clean it frequently. If use ground water or tap water, limescale may accumulate in the bath, which would not only contaminate the inner bath, but also decrease the efficiency and life of heater.

6. Add water

-  Pay attention not to overflow when adding water. Moreover, if water drops on the operation panel, use towel to wipe it. Otherwise it may cause electric leakage or electric shock.

5. Handling Precautions



7. Use under proper temperature range



The operational temperature range is Room temp. +5°C~80°C

Never set the temperature out of range.

8. At night or not use for a long time



If at night or not use for a long time, please turn the ELB to OFF.

9. Unmanned continuous operation



During unmanned continuous operation, please set automatic feed-water device (not standard accessory, level controller OBF10, code 221570), and pay attention not to have the bath empty.

10. Pay attention no-load operation (action of overheat protector)



Please do not operate when no water in the bath or heater is not submerged by water.

Besides the heater would become red and hot and reduce its life, it may cause fire. Please confirm the water volume of bath and add water moderately before using. The overheat protector is set in the device, if no-load operating, it would automatically cut off the power connected with heater. After no-load operation, please contact Yamato Business Office or Customer Service Center.

11. Recovering after power failure



When power is supplied after a power failure, the device automatically starts operation again with the same state as just before the power failure.

12. After installation



It may cause injure to a person if this unit falls down or moves by the earthquake and the impact. etc.. To prevent, take measures that the unit cannot fall down.

6. Maintenance Method

Daily Inspection and Maintenance

Warning

- Be sure to pull out the power cord except under special circumstances before trying to do inspection and maintenance works.
- Start these works after the device has returned to the normal temperature.
- Never try to disassemble the unit.

Caution

- Wipe off the dirt on resin parts or operation panel with a tightly wrung soft cloth. Never clean the unit with gasoline, banana oil or detergent, otherwise it may result in deformation, deterioration or discolor.

Every month

- Please inspect the ELB performance regularly.
 - Power on to test
 - Firstly, turn ELB on
 - Then, use a tip (like pencil tip) to press the test switch of ELB. If ELB breaks off, it's normal.

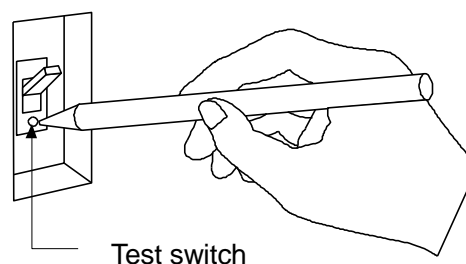

Maintenance of water bath

Continuous operation would concentrate the circulation fluid and accelerate the adhesion of limescale. When the water bath is smudged by incrustation or limescale, scoop water out or exhaust water through water exhaust valve, and then clean the bath.

It's better to use ion exchange water or distilled water, and clean it frequently. If use ground water or tap water, incrustation or limescale may accumulate in the bath, and it would may decrease the efficiency and life of heater.

- ◆ If have any problems, please contact dealer, Yamato Business Office or Customer Service Center.

Maintenance of circulating pump

Please carefully clean out the foreign matters or glassware fragments in the bath, otherwise it may cause circulating pump damage.

- ◆ If have any problems, please contact dealer, Yamato Business Office or Customer Service Center.

Replacement of hose

In order to use this unit stably, it's better to replace the hose every two week. Consult Yamato when replacing.

- ◆ If have any problems, please contact dealer, Yamato Business Office or Customer Service Center.

7. Long storage and disposal

When not using this unit for long term / When disposing



Caution

When not using this unit for long term

- Turn off the power and disconnect the power cord.



Warning

When disposing

- Keep out of reach of children.
- Remove the door and driving parts.
- Treat as large trash.

Disposal Notice

Environmental protection should be considered

We request you to disassemble this unit as possible and recycle the reusable parts considering to the environmental protection. The feature components of this unit and materials used are listed below.

Main Component Name	Material
Main Components of Exterior	
Exterior	Iron steel plate
Interior	Stainless steel SUS304
Observation window	Semi-strengthened glass
Support rest	Aluminum casting
nameplate	PET resin film
Frame/angle of operation parts	ABS resin
Decorative rubber, rubber plate	Chloroprene rubber
Main Electrical Parts	
Switch, relay	Resin, copper and other compound
Board	Glass fiber and other compound
Heating pipe	Copper
Power cord	Compound like Synthetic rubber, copper, nickel, etc.
Main piping components	
Hose	Ethylene propylene rubber
Water exhaust hose	PVC resin
Hose clamp	66 nylon
Drainage cap	POM
Accessories	
Connector	Aluminum casting
Flask clamp	Aluminum casting
Support	SUS304

8. In the Event of Failure

Safety Device and Error Code

This unit has an automatic diagnosis function built in the controller and safety devices independent of the controller. The table below shows the cause and the solution method when the safety device operates.

Error Code

When an abnormal condition occurs, an error code appears and the alarm lamp lights in the controller, the buzzer sounds simultaneously. Record the error code and turn off the power of device immediately.

Safety Device	Notify	Cause/Solution
Sensor trouble detection	"ALARM" lamp lights on, "Er.01" appears	<ul style="list-style-type: none"> • Temperature sensor is broken or disconnected. • Make a call for service.
SSR short-circuit detection	"ALARM" lamp lights on, "Er.02" appears	<ul style="list-style-type: none"> • Triac is in short-circuit • Make a call for service.
Heater disconnecting detection	"ALARM" lamp lights on, "Er.03" appears	<ul style="list-style-type: none"> • Heater is disconnected. • Make a call for service.
Memory error	"ALARM" lamp lights on, "Er.15" appears	<ul style="list-style-type: none"> • Failure in internal memory. • Make a call for service.
Internal communication error	"ALARM" lamp lights on, "Er.17" appears	<ul style="list-style-type: none"> • Failure in internal communication or temperature inputting circuit. • Make a call for service.
Overheating	"ALARM" lamp lights on, "Er.19" appears	<ul style="list-style-type: none"> • Overheating prevention device is in operation. • Reset the power supply, and then adjust the setting temperature of the overheating protection device. • If the state does not recover, make a call for service.
Measurement temperature error	"ALARM" lamp lights on, "----" appears	<ul style="list-style-type: none"> • Measurement value is out of display range. • Make a call for service.

8. In the Event of Failure

Trouble Shooting

If any of the symptoms below occurs:

Symptom	Check
Turning the ELB to on will not activate the unit.	<ul style="list-style-type: none">● If the power cord is connected to the power supply securely.● If power outage is not occurring.
Temperature does not rise.	<ul style="list-style-type: none">● If the set temperature is below that in the chamber.● If the power supply voltage has declined.● If the ambient temperature is low.● If cooling load inside the chamber is too large.
Temperature fluctuates during operation.	<ul style="list-style-type: none">● If the set temperature is appropriate.● If the power supply voltage has declined.● If ambient temperature fluctuates widely.● If the load inside the chamber is getting large.
Displayed temperature differs from the measurement.	<ul style="list-style-type: none">● If the calibration offset setting is not other than "0". Set it to "0." Confirm settings in "Other Functions" on page 23.
Circulating pump has abnormal noise	<ul style="list-style-type: none">● If the air does not enter the circulating pump. Cut off the power temporarily, inject water through the inlet of circulating pump to exhaust the air.

- ◆ In the case if the error other than listed above occurred, turn off the power switch and primary power source immediately. Contact the shop of your purchase or Yamato Scientific Chongqing.

9. After Service and Warranty

When requesting a repair

When requesting a repair

If any trouble occurs, immediately stop operation, turn the ELB off, pull out the power plug and contact your dealer or our sales office.

Information necessary for requesting a repair

- ◆ Model name of the product
 - ◆ Serial number
 - ◆ Date (y/m/d) of purchase
 - ◆ Description of trouble (as in detail as possible)
- } Confirm on the warranty card or the nameplate installed on the unit.

Be sure to indicate the warranty card to our service representative.

Warranty card (attached separately)

- Warranty card is given by your dealer or one of our sales offices and please fill in your dealer, date of purchase and other information and store securely.
- Warranty period is one full year from the date of purchase. Repair service for free is available according to the conditions written on the warranty card.
- For repairs after the warranty period consult your dealer or one of our sales offices. Paid repair service is available on your request when the product's functionality can be maintained by repair.

Minimum holding period of repair parts

The minimum holding period of repair parts for this product is seven years after end of production. Repair parts here refer to parts necessary for maintaining performance of the product.

※1

10. Specification

Model		BK310C	BK410C	BK510C	BK610C	BK710C
System		Forced pump water circulation				
Performance	Temp. operating range	RT+5°C~80°C				
	Temp. adjusting accuracy	±0.02~±0.07°C (at 80°C)				
	Temp. distribution accuracy	±0.3°C (at 80°C)				
	※1 Temp. rise time~80°C	Approx.120min	Approx.110 min	Approx.165 min	Approx.160 min	Approx.200 min
Structure	Exterior	Cold-rolled steel plate with coating				
	Interior	Stainless steel and glass				
	Heater	SUS pipe heater				
		1.3kW	2.2kW	2.4kW	3.5kW	4.5kW
	Stirrer	Magnetic pump				
		6W	30W	60W		
Observation window	Strengthened glass×2					
Control parts	Controller	VS6 temperature controller				
	Control system	PID control for heater output by microcomputer				
	Setting system	Digital setting by menu key and up/down keys				
	Display system	Measured temp. display: green 4-line LED digital display				
		Set temp. display: red 4-line LED digital display				
	Time	1min-99hr59min and 100hr-999.5hr (with timing function)				
	Time resolution	1min and 10min				
	Operation mode	Fixed temperature, Quick auto stop, Auto stop, Auto start				
	Sensor	The sensors of control and overheat protector are the same type				
Additional functions	Lock function, Auto recovering after power failure, Calibration offset					
Safety device	Self-diagnosis functions	Failure of temperature sensor, heater, display, SSR, automatic overheating prevention, measured temperature				
	Safety device	Circuit breaker, Overheating prevention device (controller all-in-one electronic type)				
Spec.	External dimension (mm) ※2 (WxDxH)	490×360× 367	590×410× 367	690×460× 417	738×560× 467	830×560×5 17
	Internal dimension (mm) ※2(WxDxH)	300×300× 300	400×350× 300	500×400× 350	548×500× 400	640×500×4 50
	Observation window dimension	240×215	340×215	440×265	340×215	440×265
	Bath Capacity (L)	Approx.27	Approx.42	Approx.70	Approx.109	Approx.144
	Diameter of drain hose	φ15×20mm				
	Power capacity (single phase AC220V 50Hz)	6 A	10.5 A	11.5 A	16.5 A	21 A
	Weight	Approx.19Kg	Approx.25Kg	Approx.30Kg	Approx.36Kg	Approx.46Kg
Accessories	Shelf plate×1, clamping device×2, stand×1, clamping device support×2, Instruction Manual, Warranty					

※1 The performance under the condition of AC 220V power source, RT 23°C ±5°C, humidity 65% RH±5%, unloaded and exhaust port fully closed. The operating ambient temperature of the unit is from 5°C to 35°C.

※2 Exclude bulges.

11. Wiring Diagram

BK310C/410C/510C/610C

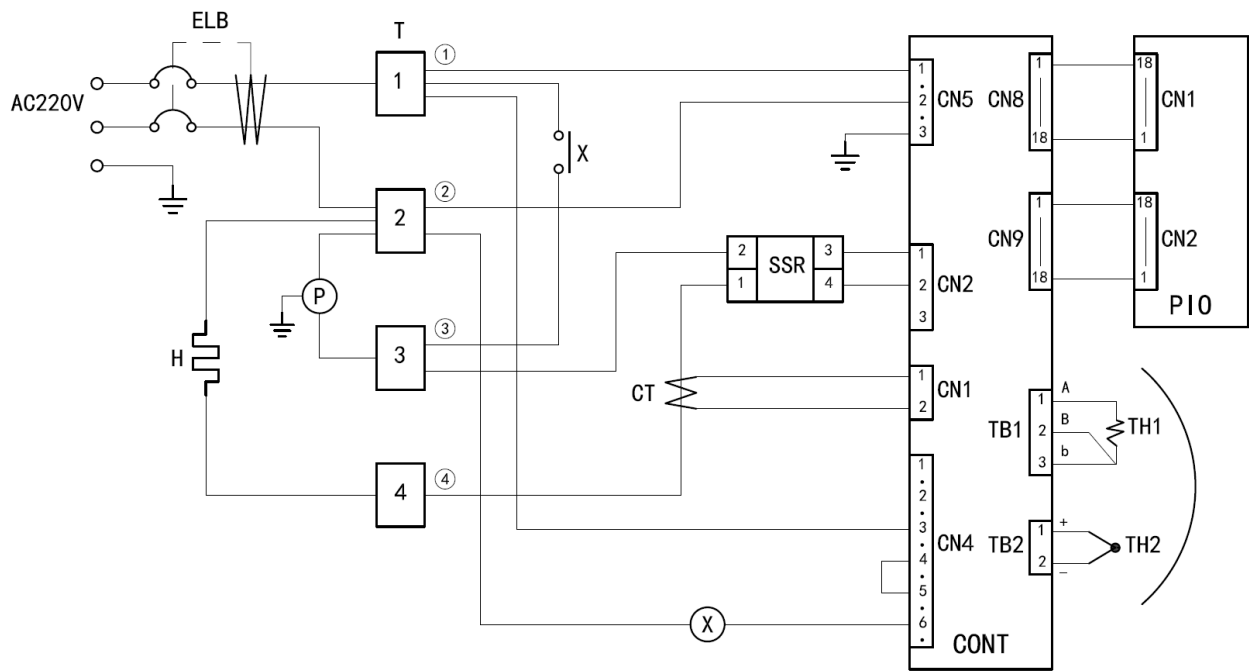

Symbol	Part name	Symbol	Part name
ELB	Earth Leakage Breaker	CONT	Control board
T	Terminal block	PIO	Display board
H	Heater	TH1	Sensor for control
X	AC relay	TH2	Sensor for overheating prevention
P	Magnetic pump	CT	Current transformer
SSR	Solid state relay		

11. Wiring Diagram

BK710C

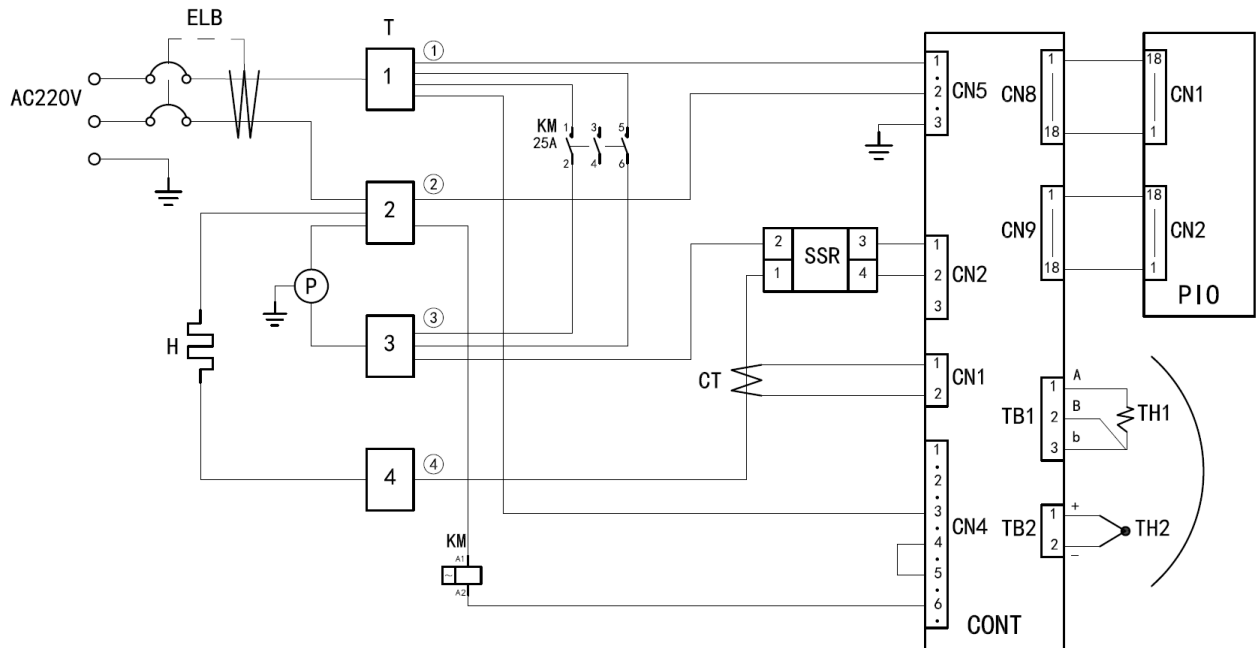

Symbol	Part name	Symbol	Part name
ELB	Earth Leakage Breaker	CONT	Control board
T	Terminal block	PIO	Display board
H	Heater	TH1	Sensor for control
KM	AC contactor	TH2	Sensor for overheating prevention
P	Magnetic pump	CT	Current transformer
SSR	Solid state relay		

12. Replacement Parts Table

BK310C/410C/510C/610C/710C Common replacement parts

Symbol	Part Name	Specification	Manufacturer	Code No.
TH1, 2	Temperature sensor	PT100/B K ϕ 4.8x125L R1/8	YSJ	A010502034
CONT	Control board	VS6	YSJ	B011401053
PIO	Display board	VS	YSJ	B011402007
	Signal cable	VS3·VS4 15P 40mm	YSJ	B011299007
CT	Current transformer	CTL-6-S-4	YSJ	B010509001

BK310C Replacement parts

Symbol	Part Name	Specification	Manufacturer	Code No.
ELB	Earth Leakage Breaker	BV-DN IP+N 10A 30mA	YSJ	A010410007
X1	AC relay	HF116F-2/220AL1HSTFW	YSJ	A011002002
SSR	Solid state relay	KS15/D-38Z25-L	YSJ	A011006023
H	Heater	220V 1.3KW	YSJ	H040701024
P	Magnetic pump	MD-6-230GS01 AC220V	YSJ	A042102004

BK410C Replacement parts

Symbol	Part Name	Specification	Manufacturer	Code No.
ELB	Earth Leakage Breaker	BV-DN IP+N 16A 30mA	YSJ	A010410004
X1	AC relay	HF116F-2/220AL1HSTFW	YSJ	A011002002
SSR	Solid state relay	KS15/D-38Z25-L	YSJ	A011006023
H	Heater	220V 2.2KW	YSJ	H040701002
P	Magnetic pump	MD-20R-220-N	YSJ	A042102007

BK510C Replacement parts

Symbol	Part Name	Specification	Manufacturer	Code No.
ELB	Earth Leakage Breaker	BV-DN IP+N 16A 30mA	YSJ	A010410004
X1	AC relay	HF116F-2/220AL1HSTFW	YSJ	A011002002
SSR	Solid state relay	KS15/D-38Z25-L	YSJ	A011006023
H	Heater	220V 2.4KW	YSJ	H040701021
P	Magnetic pump	MD-20R-220-N	YSJ	A042102007

12. Replacement Parts Table

BK610C Replacement parts

Symbol	Part Name	Specification	Manufacturer	Code No.
ELB	Earth Leakage Breaker	BV-DN 1P+N 20A 30mA	YSJ	A010410001
X1	AC relay	HF116F-2/220AL1HSTFW	YSJ	A011002002
SSR	Solid state relay	KS15/D-38Z40-L	YSJ	A011006024
H	Heater	220V 3.5KW	YSJ	H040701026
P	Magnetic pump	D-40R-220-N AC220V	YSJ	A042102005

BK710C Replacement parts

Symbol	Part Name	Specification	Manufacturer	Code No.
ELB	Earth Leakage Breaker	BV-DN 1P+N 25A 30mA	YSJ	A010410002
KM	AC contactor	LC1-D25M7C	YSJ	A011003008
SSR	Solid state relay	KS15/D-38Z40-L	YSJ	A011006024
H	Heater	220V 4.5KW	YSJ	H040701015
P	Magnetic pump	MD-40R-220-N AC220V	YSJ	A042102005

13. List of Dangerous Substances



Never use explosive substances, flammable substances and substances that include explosive or flammable ingredients in this unit.

EXPLOSIVE

EXPLOSIVE:	Ethylene glycol dinitrate (nitro glycol), Glycerin trinitrate (nitroglycerine), Cellulose nitrate (nitrocellulose), and other explosive nitrate esters
	Trinitrobenzene, Trinitrotoluene, Trinitrophenol (picric acid), and other explosive nitro compounds
	Acetyl hidroperoxide (peracetic acid), Methyl ethyl ketone peroxide, Benzyl peroxide, and other organic peroxides

FLAMMABLE

IGNITING:	Lithium (metal), Potassium (metal), Sodium (metal), Yellow phosphorus, Phosphorus sulfide, Red phosphorus, Celluloid compounds, Calcium carbide, Lime phosphate, Magnesium (powder), Aluminum (powder), Powder of metals other than magnesium and aluminum, Sodium hydrosulfite
OXIDIZING:	Potassium chlorate, Sodium chlorate, Ammonium chlorate, and other chlorate
	Potassium perchlorate, Sodium perchlorate, Ammonium perchlorate, and other perchlorate
	Potassium peroxide, Sodium peroxide, Barium peroxide, and other inorganic peroxide
	Potassium nitrate, Sodium nitrate, Ammonium nitrate, and other nitrate
	Sodium chlorite and other chlorites
INFLAMMABLE LIQUID:	Calcium hypochlorite and other hypochlorites
	Ethyl ether, Gasoline, Acetaldehyde, Propylene chloride, Carbon disulfide, and other flammable substances having a flash point of lower than -30°C
	Normal hexane, ethylene oxide, acetone, benzene, methyl ethyl ketone, and other flammable substances having a flash point of -30°C or higher but lower than 0°C
	Methanol, Ethanol, Xylene, Pentyl acetate (amyl acetate), and other flammable substances having a flash point of 0°C or higher but lower than 30°C
FLAMMABLE GAS:	Kerosene, Light oil (gas oil), Oil of turpentine, Isopentyl alcohol (isoamyl alcohol), Acetic acid, and other flammable substances having a flash point of 30°C or higher but lower than 65°C
	Hydrogen, Acetylene, Ethylene, Methane, Propane, Butane, and other flammable substances which assume a gaseous state at 15°C and 1 atm

14. Installation Manual

Install the product according to the following: (Confirm separately for optional items or special specifications)

Model	Serial number	Date	Installation mgr. (company name)	Installation mgr.	Judgment

No.	Item	Implementation method	TOC No. Reference page of the operating instruction manual	Judgment
Specifications				
1	Included items	Check for number of staffs against the included item field	10. Specifications field P.32	
2	Installation	<ul style="list-style-type: none"> Visual check of environmental conditions Caution: Take care for environment 	2. Before operating the unit P.4 <ul style="list-style-type: none"> On the installation site 	
		<ul style="list-style-type: none"> Securing a space 		
Operation-related matters				
1	Source voltage	<ul style="list-style-type: none"> Measure the user side voltage (outlet) with a tester Measure voltage during operation (shall meet the standard) Caution: Always use a plug that meets the specification for attaching to the ELB. 	2. Before operating the unit P.4 <ul style="list-style-type: none"> Be sure to connect the ground wire. P.7 Power supply is P.32 10.Specifications <ul style="list-style-type: none"> Specification-power supply 	
2	Operation start	<ul style="list-style-type: none"> Starts operation Performs fixed value operation, auto stop operation or auto start operation 	2. Before operating the unit P.4~7 <ul style="list-style-type: none"> Installation procedures... P.12~ 4. Operating procedures 24	
Description				
1	Operational descriptions	Explain operations of each component according to the operational instructions	4. Operating procedures P.12~ <ul style="list-style-type: none"> Operating procedures 24 1.Safety precautions~ P.1~37 13. List of dangerous materials	
2	Error codes	Explain the customer about error codes and procedures for release according to the operational instructions	8. Troubleshooting ~ 9. After sales service and warranty P.29~31	
3	Maintenance and inspection	Explain operations of each component according to the operational instructions	6. Maintenance procedures P.27 <ul style="list-style-type: none"> Daily inspection/maintenance 	
4	Completion of installation Record items	<ul style="list-style-type: none"> Fill in the installation date and the installation mgr. on the nameplate of the main unit Fill in necessary information items to the warranty card and hand it over to the customer Explanation of the route for after-sales service 	9. After sales service and warranty P.31	

Responsibility

Please follow the instructions in this document when using this unit. Yamato Scientific has no responsibility for the accidents or breakdown of device if it is used with a failure to comply. Never conduct what this document forbids. Unexpected accidents or breakdown may result in.

Note

- ◆ The contents of this document may be changed in future without notice.
- ◆ Any books with missing pages or disorderly binding may be replaced.

Instruction Manual

Constant High Temperature Water Bath

BK310C/410C/510C/610C/710C

First Edition May 28, 2018

Revision July 11, 2023

YAMATO SCIENTIFIC CO., LTD.
Harumi Triton Square Y-36F, 1-8-11 Harumi,
Chuo-ku, Tokyo 104-6136, Japan
Tel : +81-3-5548-7122
Fax : +81-3-5548-0132
<https://www.yamato-scientific.com/>